

UK

ENSURE THAT THESE INSTRUCTIONS ARE LEFT
FOR THE USER AFTER COMPLETION OF THE
BENCHMARK SECTION



WRAS
APPROVED
PRODUCT

ECOMFORT PLUS HE -EV

*Installation and
servicing instructions*



Please read the Important Notice within
this guide regarding your boiler warranty



IMPORTANT NOTICE

For the first year all of our appliances are protected by our manufacturer's guarantee which covers both parts and labour.

As you would expect from Sime Ltd, it is our aim to provide our valued customers with the best in after sales and service.

To take advantage of any extended warranty offered, all you have to do is to adhere to these 3 simple conditions:

- The installation must be carried out to Manufacturers/Benchmark Standards by a Gas Safe Registered Engineer, and recorded in the installation manual.
- The appliance must be registered with both Sime Ltd and Gas Safe within 30 days of installation.
- The appliance must be serviced annually, by either Sime Ltd or a Gas Safe registered engineer- ensuring that the Benchmark service record in the installation manual is completed.

Failure to comply with the above will result in only the 12 month warranty being offered.

In the absence of any proof of purchase, the 12 month warranty period will commence from the date of manufacture of the boiler as shown on the appliance data plate.

SAFE HANDLING

This boiler may require 2 or more operatives to move it into its installation site, remove it from its packaging and during movement into its installation location. Manoeuvring the boiler may include the use of a sack truck and involve lifting pushing and pulling.

Caution should be exercised during these operations.

Operatives should be knowledgeable in handling techniques when performing these tasks and the following precautions should be considered:

- Grip the boiler at the base
- Be physically capable
- Use personal protective equipment as appropriate e.g. gloves, safety footwear.

During all manoeuvres and handling actions, every attempt should be made to ensure the following unless unavoidable and/or the weight is light.

- Keep back straight
- Avoid twisting at the waist
- Always grip with the palm of the hand
- Keep load as close to the body as possible
- Always use assistance

WARNING

Caution should be exercised when performing any work on this appliance.

Protective gloves and safety glasses are recommended.

- Avoid direct contact with sharp edges.
- Avoid contact with any hot surfaces.

NOTICE

Please be aware that due to the wet testing of the appliance, there may be some residual water in the hydraulic circuit.

- Protect any surfaces, carpets or floorings.
- Use a suitable container to catch any water that escapes when removing the protective caps from the connections.

Code Of Practice

For the installation, commissioning and servicing
of domestic heating and hot water products

Benchmark places responsibilities on both manufacturers and installers.* The purpose is to ensure that customers** are provided with the correct equipment for their needs, that it is installed, commissioned and serviced in accordance with the manufacturer's instructions by competent persons and that it meets the requirements of the appropriate Building Regulations. Installers are required to carry out work in accordance with the following:

Standards of Work

- Be competent and qualified to undertake the work required.
- Install, commission, service and use products in accordance with the manufacturer's instructions provided.
- Ensure that where there is responsibility for design work, the installation is correctly sized and fit for purpose.
- Meet the requirements of the appropriate Building Regulations. Where this involves notifiable work be a member of a Competent Persons Scheme or confirm that the customer has notified Local Authority Building Control (LABC), prior to work commencing.
- Complete all relevant sections of the Benchmark Checklist/Service Record when carrying out commissioning or servicing of a product or system.
- Ensure that the product or system is left in a safe condition and, whenever possible, in good working order.
- Highlight to the customer any remedial or improvement work identified during the course of commissioning or servicing work.
- Refer to the manufacturer's helpline where assistance is needed.
- Report product faults and concerns to the manufacturer in a timely manner.

Customer Service

- Show the customer any identity card that is relevant to the work being carried out prior to commencement or on request.
- Give a full and clear explanation/demonstration of the product or system and its operation to the customer.
- Hand over the manufacturer's instructions, including the Benchmark Checklist, to the customer on completion of an installation.
- Obtain the customer's signature, on the Benchmark Checklist, to confirm satisfactory demonstration and receipt of manufacturer's instructions.
- Advise the customer that regular product servicing is needed, in line with manufacturers' recommendations, to ensure that safety and efficiency is maintained.
- Respond promptly to calls from a customer following completion of work, providing advice and assistance by phone and, if necessary, visiting the customer.
- Rectify any installation problems at no cost to the customer during the installer's guarantee period.



*The use of the word "installer" is not limited to installation itself and covers those carrying out installation, commissioning and/or servicing of heating and hot water products, or the use of supporting products (such as water treatment or test equipment).

**Customer includes householders, landlords and tenants.

The Benchmark Scheme

Sime Ltd is a licensed member of the Benchmark Scheme which aims to improve the standards of installation and commissioning of domestic heating and hot water systems in the UK and to encourage regular servicing to optimise safety, efficiency and performance.

Benchmark is managed and promoted by the Heating and Hotwater Industry Council.
For more information visit www.centralheating.co.uk



ECOMFORT PLUS 25 HE -EV: Gas Council number 47-283-30

ECOMFORT PLUS 30 HE -EV: Gas Council number 47-283-31

ECOMFORT SYSTEM PLUS 25 HE -EV: Gas Council number 41-283-26

ECOMFORT PLUS 25 HE -EV (without time clock): Gas Council number 47-283-32

ECOMFORT PLUS 30 HE -EV (without time clock): Gas Council number 47-283-33

These appliances comply with the S.E.D.B.U.K. scheme, band "A"

CONTENTS

1	DESCRIPTION OF THE BOILER	pag. 6
2	INSTALLATION	pag. 10
3	CHARACTERISTICS	pag. 21
4	USE, MAINTENANCE (including BENCHMARK) AND COMMISSIONING	pag. 25
5	FAULT FINDING	pag. 32
6	REPLACEMENT OF PARTS	pag. 33
7	EXPLODED VIEWS	pag. 35

Important Information

IT IS A STATUTORY REQUIREMENT THAT ALL GAS APPLIANCES ARE INSTALLED BY COMPETENT PERSONS, IN ACCORDANCE WITH THE GAS SAFETY (INSTALLATION AND USE) REGULATIONS (CURRENT EDITION). The manufacturer's instructions must not be taken as overriding any statutory requirements, and failure to comply with these regulations may lead to prosecution.

No modifications to the appliance should be made unless they are fully approved by the manufacturer.

GAS LEAKS: DO NOT OPERATE ANY ELECTRICAL SWITCH, OR USE A NAKED FLAME. TURN OFF THE GAS SUPPLY AND VENTILATE THE AREA BY OPENING DOORS AND WINDOWS CONTACT THE GAS EMERGENCY SERVICE ON 0800111999.



Please refer to commissioning instructions for filling in the checklist at the back of this installation guide.

Note: All Gas Safe registered installers carry a ID Card.

You can check your installer is Gas Safe Registered by calling 0800 408 5577

SIME COMBINATION BOILERS Installer checklist

Please remember to carry out the following checks after installation. This will achieve complete customer satisfaction, and avoid unnecessary service calls. A charge will be made for a service visit where the fault is not due to a manufacturing defect.

- Has a correct by-pass been fitted and adjusted?
- Has the system and boiler been flushed?
- Is the system and boiler full of water, and the correct pressure showing on the pressure gauge?
- Is the Auto Air Vent open?
- **Has the pump been rotated manually?**
- Is the gas supply working pressure correct?
- Is the boiler wired correctly? (See installation manual).
- **Has the D.H.W. flow rate been set to the customer requirements?**
- Has the customer been fully advised on the correct use of the boiler, system and controls?
- Has the Benchmark Checklist in the use and maintenance section of this manual, been completed ?

1 DESCRIPTION OF THE BOILER

1.1 INTRODUCTION

ECOMFORT PLUS HE -EV and **ECOMFORT SYSTEM PLUS HE -EV** boilers have a condensing heat exchanger downstream from the fan to allow the heat contained in

exhaust fumes to be recovered. The boiler is equipped as standard with frost protection and circulating pump antijamming system.

The instructions given in this manual are provided to ensure proper installation and

correct operation of the appliance.

All modules are compliant with European Directives 2009/142/CE, 2004/108/CE, 2006/95/CE and 92/42/CE.

1.2 DIMENSIONS (Fig. 1)

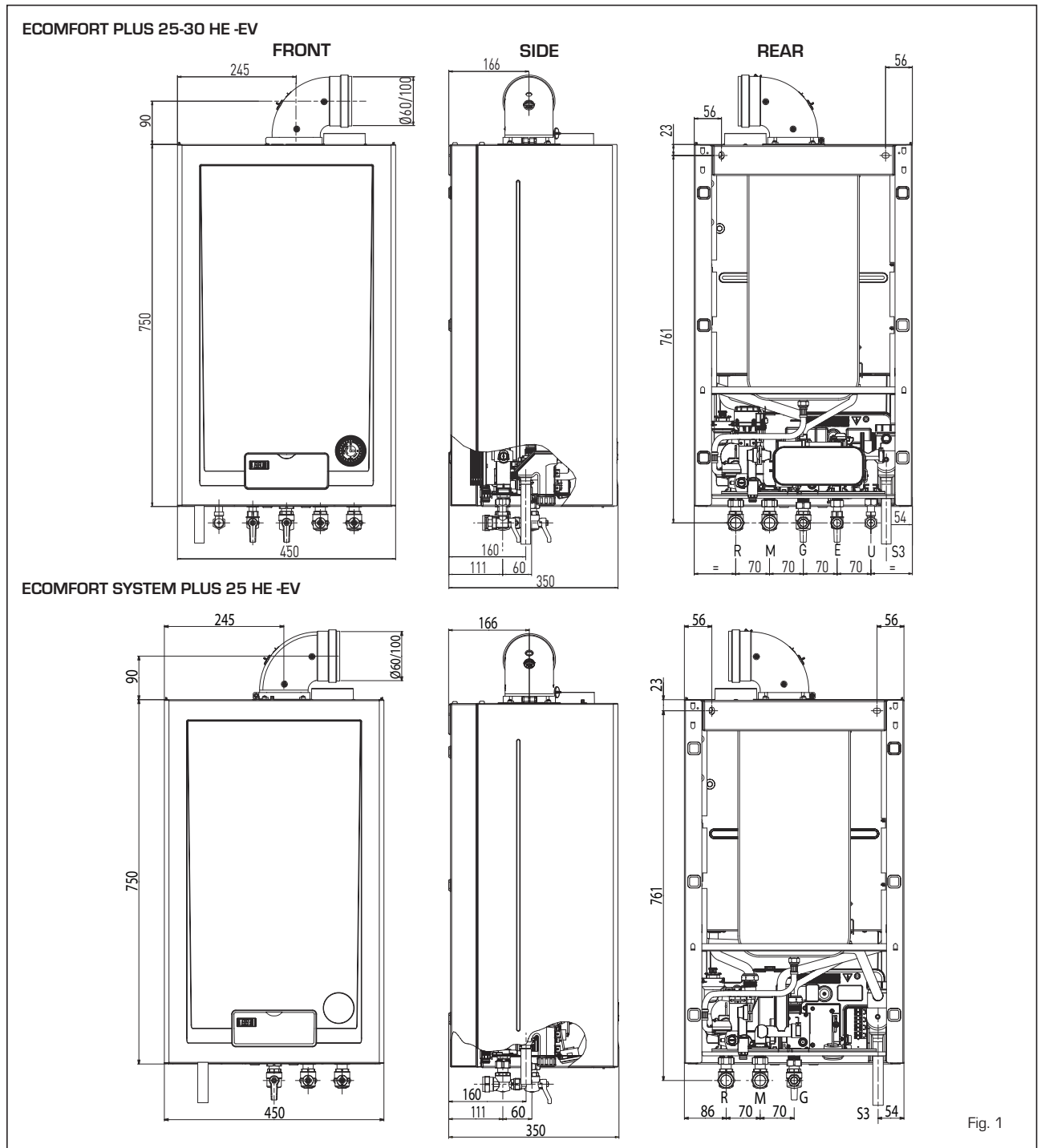

Fig. 1

TABLE 1 - Connections

R	C.H. return	22 mm	Compression
M	C.H. flow	22 mm	Compression
G	Gas connection	15 mm	Compression
E	D.H.W. inlet	15 mm	Compression
U	D.H.W. outlet	15 mm	Compression
S3	Condensation outlet \varnothing 20		

TABLE 2 - Minimum clearances

	For servicing
ABOVE THE APPLIANCE CASING	300 mm
AT THE R.H.S.	15 mm
AT THE L.H.S.	15 mm
BELOW THE APPLIANCE CASING	200 mm
IN FRONT OF THE APPLIANCE	500 mm

1.3 TECHNICAL FEATURES (Table 3)

ECOMFORT PLUS		25 HE -EV	30 HE -EV	SYSTEM 25 HE -EV
Code boiler (with mechanical clock)		8104022	8104021	-
Code boiler without time clock		8104026	8104025	8104030
Heat output nominal (80-60°C)	kW	25.0	29.0	25,0
Heat output nominal (50-30°C)	kW	27.2	31.5	27,2
Heat output minimum (80-60°C)	kW	9.6	11.3	9,6
Heat output minimum (50-30°C)	kW	10.2	12.0	10,2
Heat input nominal	kW	25.5	29.5	25,5
Heat input minimum	kW	10.2	12.0	10,2
Efficiency min./nom. output (80-60°C)	%	94.2/98.3	94.2/98.3	94,2/98,3
Efficiency min./nom. output (50-30°C)	%	100.0/106.8	100.0/106.8	100,0/106,8
Seasonal efficiency rating (SEDBUK)		(A)	(A)	(A)
Termal efficiency (CEE 92/42 directive)		★★★★	★★★★	★★★★
Class NOx		3	3	3
Smokes temperature maximum (80-60°C)	°C	60	60	60
Smokes temperature minimum (80-60°C)	°C	60	60	60
Smokes temperature maximum (50-30°C)	°C	40	40	40
Smokes temperature minimum (50-30°C)	°C	40	40	40
Smokes flow	kg/h	58.0	61.0	58,0
CO ₂ maximum/minimum G20	%	7.0/2.5	7.5/2.8	7,0/2,5
CO ₂ maximum/minimum G30/G31	%	8.0/2.8	8.8/3.3	8,0/2,8
Adsorbed power consumption	W	150	160	150
Electrical protection grade	IP	X4D	X4D	XD4
CE certification	n°	1312BT5040	1312BT5040	1312BT5040
Category		II ₂ H3+	II ₂ H3+	II ₂ H3+
Type		B22P-52P/C12-32-42-52-82	B22P-52P/C12-32-42-52-82	B22P-52P/C12-32-42-52-82
WEIGHT	kg	40,8	41,2	38,3
CENTRAL HEATING				
Maximum water head	bar	2,5	2,5	2,5
Maximum temperature	°C	85	85	85
Water content boiler	l	5.0	5.0	5,0
C.H. setting range	°C	40/80	40/80	40/80
Expansion vessel capacity	l	8	8	8
Expansion vessel pressure	bar	1	1	1
DOMESTIC HOT WATER				
Minimum/Maximum pressure	bar	0.4/6.0	0.4/6.0	-
D.H.W. flow rate (EN 625)	l/min	11.7	13.6	-
Continuous D.H.W. flow rate Δt: 30°C	l/min	11.9	13.8	-
Continuous D.H.W. flow rate Δt: 35°C	l/min	10.1	11.8	-
D.H.W. setting range	°C	10/60	10/60	-
GAS PRESSURE AND NOZZLES				
Gas supply pressure G20	mbar	20	20	20
Gas supply pressure G30	mbar	28-30	28-30	28-30
Gas supply pressure G31	mbar	37	37	37
Nozzles quantity	n°	12	14	12
Nozzles diameter G20	ø	1.30	1.30	1,30
Nozzles diameter G30/G31	ø	0.77	0.77	0,77
Burner gas pressure min./max. G20	mbar	2.0/11.5	2.1/11.7	2,0/11,5
Burner gas pressure min./max. G30	mbar	4.8/28.5	5.0/28.5	4,8/28,5
Burner gas pressure min./max. G31	mbar	4.8/36.5	5.0/36.5	4,8/28,5
C.H. gas consumption G20	m ³ /h	2.70	3.12	2,70
C.H. gas consumption G30/G31	kg/h	2.01	2.33	2,01

1.4 FUNCTIONAL DIAGRAM (Fig. 2)

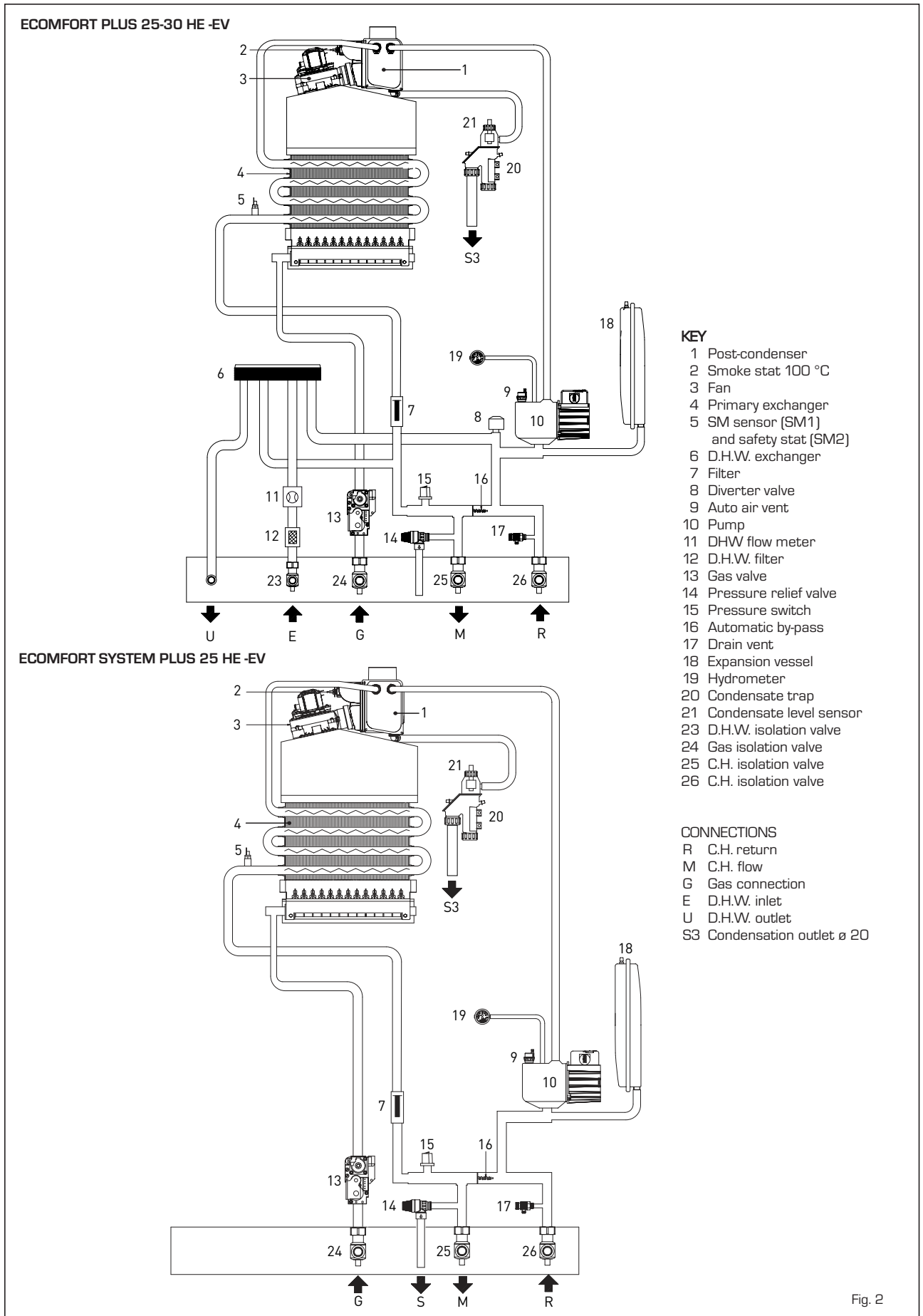
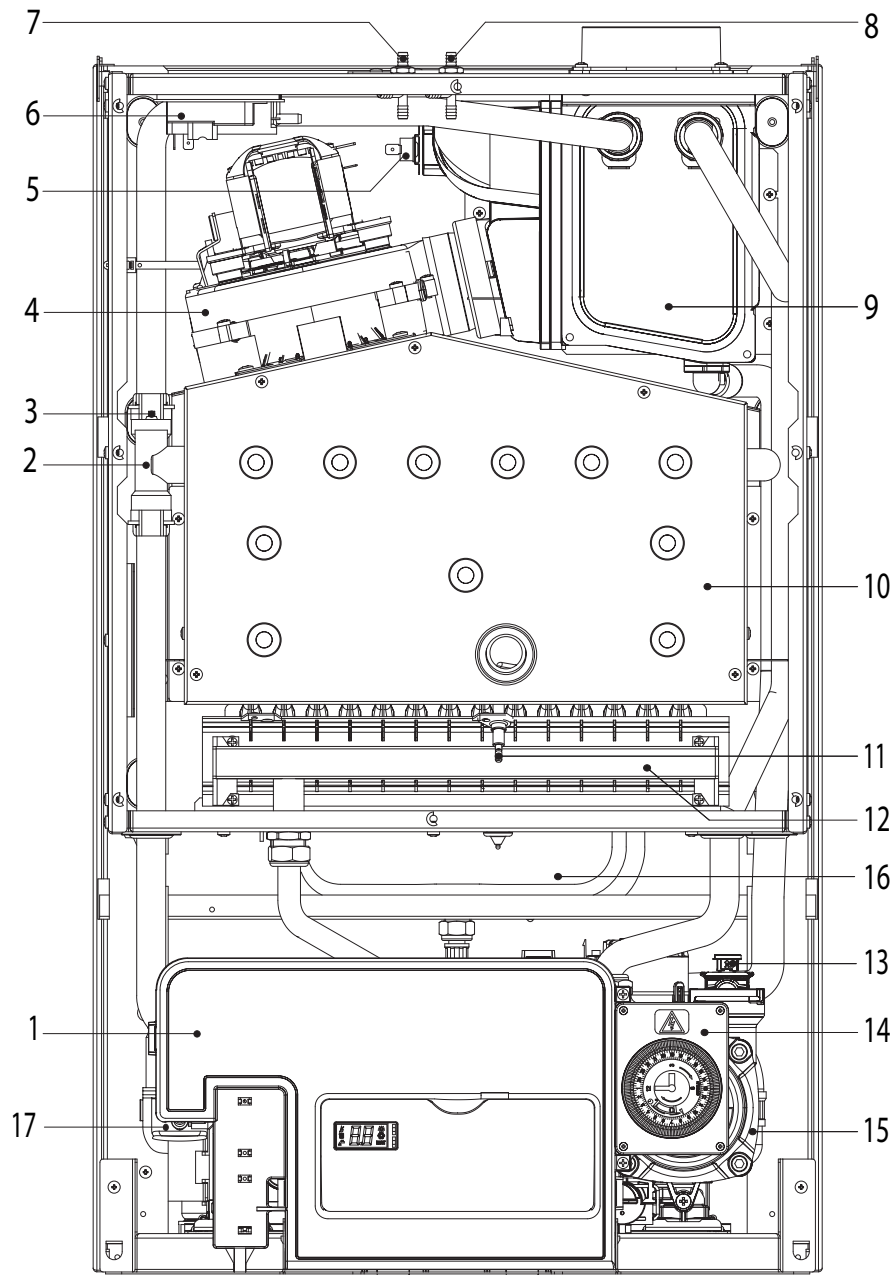

Fig. 2

1.5 MAIN COMPONENTS (Fig. 3)



NOTE: Analogue pressure gauge see fig. 18/a.

KEY

- | | |
|---------------------------------------|-----------------------------------|
| 1 Control panel | 9 Post-condenser |
| 2 Primary exchanger | 10 Combustion chamber |
| 3 SM sensor (SM1 and safety stat SM2) | 11 Ignition/ ionisation electrode |
| 4 Fan | 12 Burner |
| 5 Smoke stat 100 °C | 13 Automatic air vent |
| 6 Air pressure switch | 14 Programming clock (optional) |
| 7 Negative test point | 15 Pump |
| 8 Positive test point | 16 Expansion vessel |
| | 17 Condensate trap |

Fig. 3

2 INSTALLATION

The boiler must be installed in a fixed location and only by specialized and qualified person in compliance with all instructions contained in this manual. The boiler should be installed in accordance with the Gas Safety Regulations.

It is important that the condensate trap be filled prior to operating the boiler. The trap can be filled by pouring water carefully into the inner flue connection prior to installation of the flue. Care should be taken not to allow any water to enter the outer flue.

2.1 VENTILATION REQUIREMENTS

Detailed recommendations for air supply are given in BS5440:2. The following notes are for general guidance:

- It is not necessary to have a purpose provided air vent in the room or compartment in which the appliance is installed.

2.2 FIXING THE WALL MOUNTING BRACKET

- Using the template supplied, mark the position of the two wall mounting bracket fixing holes and the flue/air duct hole on the appropriate wall(s).
- Drill the top two fixing holes using a 10 mm masonry drill and fit the plastic plugs provided.
- Secure the wall mounting bracket in position using the screws provided. Ensure that it is the correct way up, as indicated in fig. 4.

2.3 CONNECTING UP SYSTEM

Before proceeding to connect up the boiler, you are recommended to flush out the system

in order to eliminate any foreign bodies that might be detrimental to the operating efficiency of the appliance. When making the hydraulic connections, make sure that the clearances indicated in fig. 1 are respected. To facilitate the hydraulic connections the boiler is equipped with a valve pack code 5184817A complete with instructions sheet.

A safety valve set at 3 bar is fitted to the appliance, the discharge pipe provided should be extended to terminate safely away from the appliance and where a discharge would not cause damage to persons or property but would be detected. The pipe should be a minimum of 15 mm Ø and should be able to withstand boiling water, any should avoid sharp corners or upward pipe runs where water may be retained.

Gas Connection: The gas connection must be made using seamless steel or copper pipe, galvanized and with threaded joints provided with gaskets, excluding three-piece connections, except for initial and end connections. Where the piping has to pass through walls, a suitable insulating sleeve must be provided. When sizing gas piping, from the meter to the boiler, take into account both the volume flow rates (consumption) in m³/h and the relative density of the gas in question. The sections of the piping making up the system must be such as to guarantee a supply of gas sufficient to cover the maximum demand, limiting pressure loss between the gas meter and any apparatus being used to not greater than 1.0 mbar for family II gases (natural gas). An adhesive data badge is sited inside the front panel; it contains all the technical data identifying the boiler and the type of gas for which the boiler is arranged.

Connection of condensation water trap: To ensure safe disposal of the condensate produced by the flue gases, reference should be

made to BS6798:2009.

The boiler incorporates a condensate trap which has a seal of 75mm, therefore no additional trap is required. It is recommended that 20mm waste pipe is connected to the condensate trap with the use of a 20mm solvent weld socket or elbow.

The condensate should ideally be discharged internally into an internal waste pipe(washing machine/sink waste) or a soil pipe to avoid the risk of freezing.

2.3.1 Dealing with condensate (fig.4/a)

Five suitable drainage points

It is strongly recommend that the condensate drain pipe and its termination are made internally.

Five suitable drainage points:

1. Internal drain stack pipe
2. Waste water pipe*
3. External drain or gully*
4. Rainwater hoppers that carry both rain water and foul water*
5. Purpose-made soakaways

* Care should be taken not to contaminate any "Grey Water Systems"

Pipework

Condensate pipework should be plastic, same as used for standard wastewater plumbing. The advised method of connection to the condensate trap is by using 20mm overflow pipe with a socket attached to cover the condensate trap connection. Similarly the drainage system where the condensate discharges to should also be resistant to the acid condensate.

Pipework should be kept as short as possible. External runs should be avoided, but when necessary be a minimum of 3 meter in 32 mm diameter pipework and lagged using water resistant material, to avoid freezing, this also applies to pipe runs in unheated areas such as garages.

To reduce the possibility of condensate

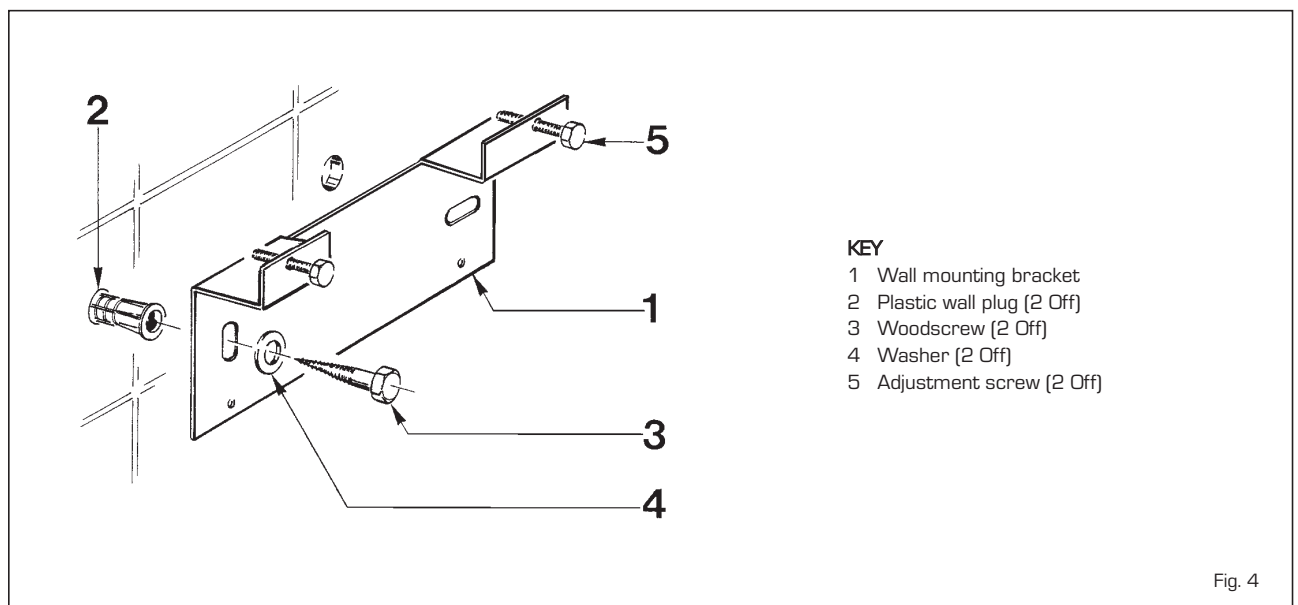

Fig. 4

being trapped in the pipe, the number of bends should be kept to a minimum. Pipework must be angled down from the boiler with a fall of at least 2.5°.

The pipework must be supported at a distance of 0.5 m for inclined runs and 1.0 m for vertical runs.

Condensate traps

Where the condensate drain is not sealed to the discharge connection a trap will be required. The water seal should be 38 mm or more for external discharge and 75 mm or more for internal discharge. When connecting to a external stack the trap should be located within the building.

Stack pipes

Condensate connections should be at least 450 mm above any bend at the bottom of a stack pipe in a single or multi-story dwelling

up to 3 storeys. There are specific requirements when connecting to a stack pipe serving multi-storey buildings greater than 3 storeys.

All connections to stack pipes should avoid across flow between other Branch pipes.

Soakaways

Any soakaways have to be purpose-made and located as close to the boiler as possible, but clear of the buildings foundations and any buried services. The best option is to purchase a soakaway from a drainage manufacturer and install it to the manufacturers recommendation.

Condensate disposal positioning and termination of the condensate drain pipe

The condensate pipe should run and terminate internally to the house soil and vent stack or waste pipe. Alternatively, the con-

densate can be discharged into the rainwater system, or into a purpose-made soak away (condensate absorption point).

An alternative condensate waste pipe should be considered where the system could be effected by extreme weather conditions. All connecting drainage pipework should have a fall of at least 2.5° to the horizontal, or approximately 50 mm per metre of pipe run.

2.3.2 Requirements for sealed water systems

The heating system design should be based on the following information:

- a) The available pump head is given in fig. 12.
- b) The burner starts when the C.H. flow reaches 400÷450 l/h. This safety condition is ensured by the flow switch.

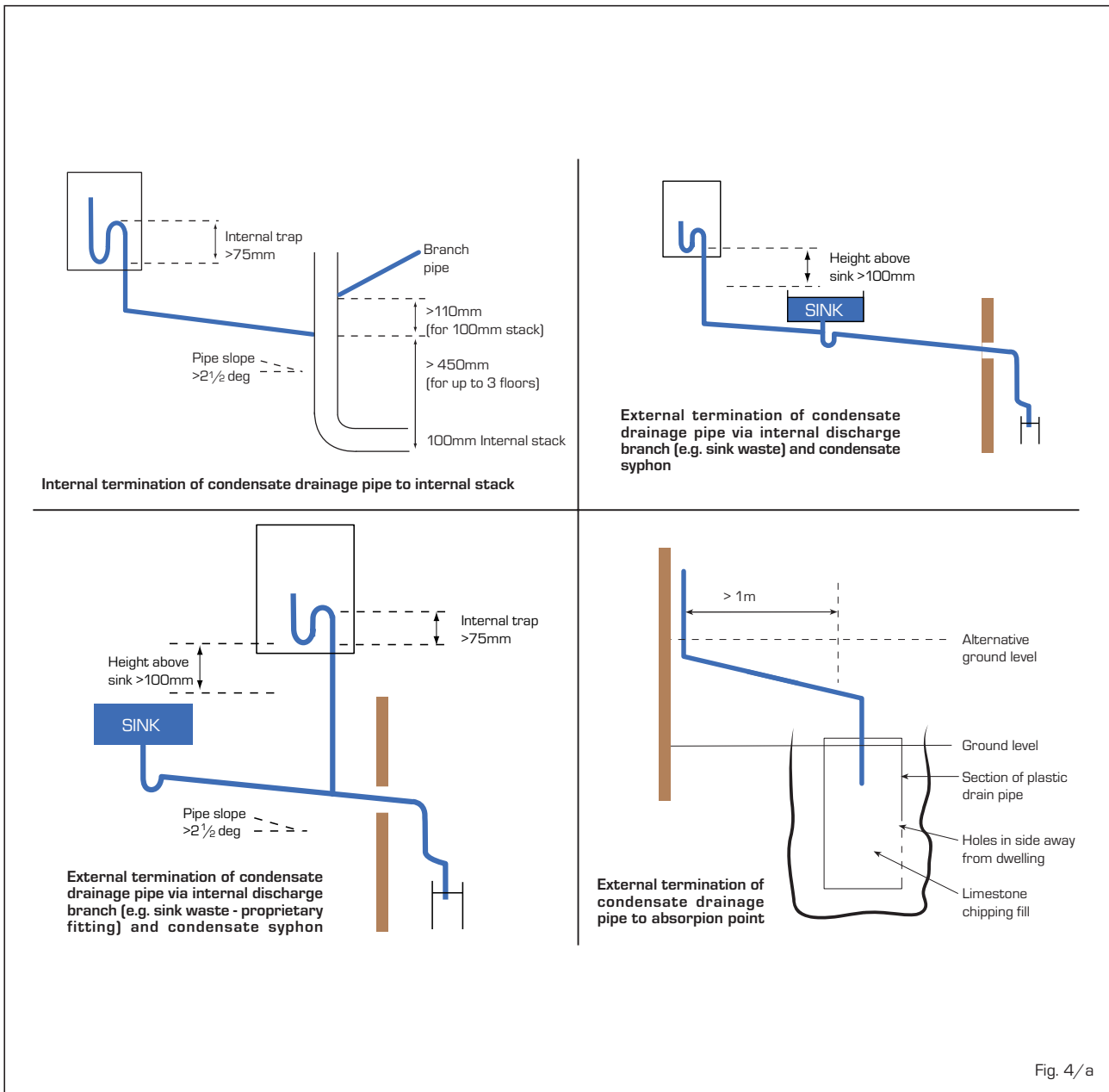

Fig. 4/a

- c) The appliance is equipped with an internal by-pass that operates with system heads (H) greater than 3 m. The maximum flow through the by-pass is about 300 l/h. If thermostatic radiator valves are to be installed, at least one radiator should be without a thermostatic valve (usually the bathroom radiator).
- d) A sealed system must only be filled by a competent person using one of the approved methods shown in fig. 4/b. The system design should incorporate the connections appropriate to one of these methods.

Fitted to the base of the boiler is an analogue pressure gauge, see fig 18/a page 25.

Ensure that the system is filled to between 1 and 1.2 bar after all the radiators are vented.

2.4 CHARACTERISTICS OF FEEDWATER

- All recirculatory systems will be subject to corrosion unless an appropriate water treatment is applied. This means that the efficiency of the system will deteriorate as corrosion sludge accumulates within the system, risking damage to pump and valves, boiler noise and circulation problems.
 - For optimum performance after installation this boiler and its associated central heating system must be flushed in accordance with the guidelines given in BS 7593 "Treatment of water in domestic hot water central heating systems".
 - This must involve the use of a proprietary cleanser, Sime Ltd recommend only the use of Fernox products for the flushing and final treatment of the system water. artificially softened water must not be used to fill the heating system.
- Failure to flush and add inhibitor to the system may invalidate the appliance warranty.**
- It is important to check the inhibitor concentration after installation, system modification and at every service in accordance with the manufacturer's instructions. (Test kits are available from inhibitor stockists).

2.5 COAXIAL DUCT \varnothing 60/100

The standard air inlet, smoke outlet assembly is part number 8096250, and is supplied complete with mounting instructions.

NOTE: Ensure that any accessories are suitable for condensing boilers.

2.5.1 Coaxial flue diaphragm

The boilers "25 HE -EV/SYSTEM 25 HE -EV" are supplied of series with diaphragm

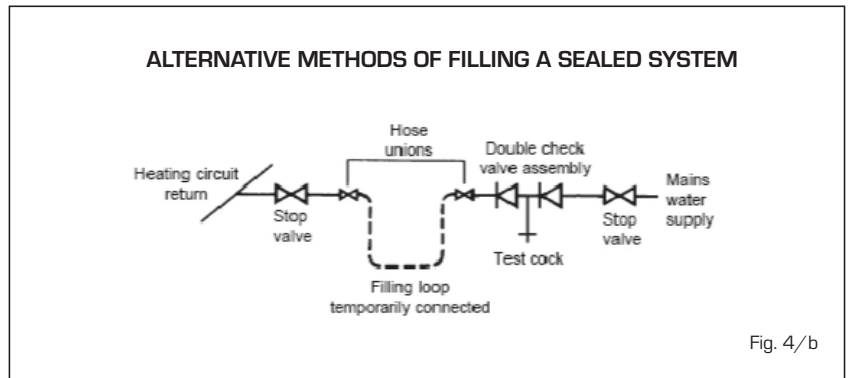

Fig. 4/b

\varnothing 87.5 to mount like indicated in figure (fig. 4/c).

ATTENTION: the diaphragm should be used only when the length of the coaxial duct is below 1,5 m (only for "25 HE -EV" and "SYSTEM 25 HE -EV" models).

2.5.2 Coaxial duct accessories

The accessories to be used for this type of installation and some of the connecting systems that may be adopted are illustrated in fig. 5.

With the bend included in the kit, the maximum length of the flue should not exceed 5.0 meter (25 HE -EV/SYSTEM 25 HE -EV) - 2.5 meter (30 HE -EV). When the vertical extension code 8086950 is used, the terminal part of the pipe must always come out horizontally.

2.6 COAXIAL DUCT \varnothing 80/125 (only for "30 HE -EV")

The air inlet-smoke outlet assembly \varnothing

80/125 is supplied in a kit code 8096253 complete with mounting instructions.

With the pipe bend included in the kit, the maximum length of the piping should not exceed 5.0 meter.

The diagrams in fig. 5 illustrate a number of examples of different coaxial outlets \varnothing 80/125.

2.7 KIT \varnothing 60/100 PLUME CODE 8096260

A special kit code 8096260 is supplied for this purpose (see fig. 5/a).

2.8 POSITIONING THE OUTLET TERMINALS

The outlet terminals for forced-draught appliances may be located in the external perimeter walls of the building.

To provide some indications of possible solutions, **Table 4** gives the minimum distances to be observed, with reference to the type of building shown in fig. 6.

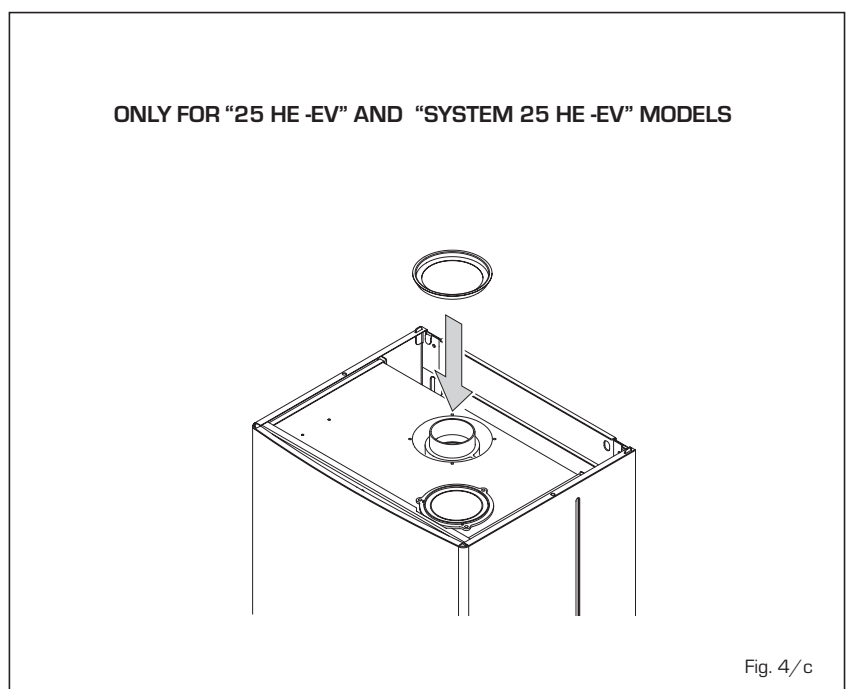

Fig. 4/c

IMPORTANT:

- The insertion of each additional 90° bend with a diameter of 60/100 (code 8095850) reduces the available section by 1.0 meters.
- The insertion of each additional 90° bend with a diameter of 80/125 (code 8095870) reduces the available section by 1,0 meters.
- Each additional 45° curve installed a diameter of 60/100 (code 8095950) reduces the available length by 0,5 metres.
- Each additional 45° curve installed a diameter of 80/125 (code 8095970) reduces the available length by 0,5 metres.

HORIZONTAL FLUES MUST BE LEVEL

NOTE: Before connecting accessories, it is always advisable to lubricate the internal part of the gaskets with silicon products. Avoid using oils and greases.

60/100 COAXIAL

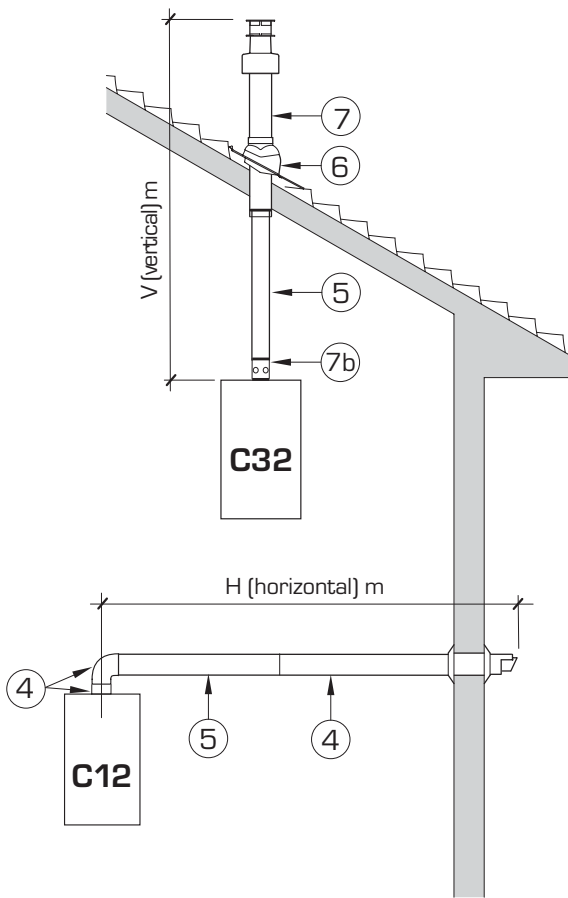

LIST OF ø 60/100 ACCESSORIES

- 4 Coaxial duct kit code 8096250
- 5 Extension L. 1000 code 8096150
- 5 Extension L. 500 code 8096151
- 6 Angle flashing plate code 8091300
- 7 Vertical terminal L. 140 code 8091212 includes item 7b
- 7b Vertical adaptor code 8086950
 - 90° degree bend code 8095850
 - 45° degree bend code 8095950

85/125 COAXIAL

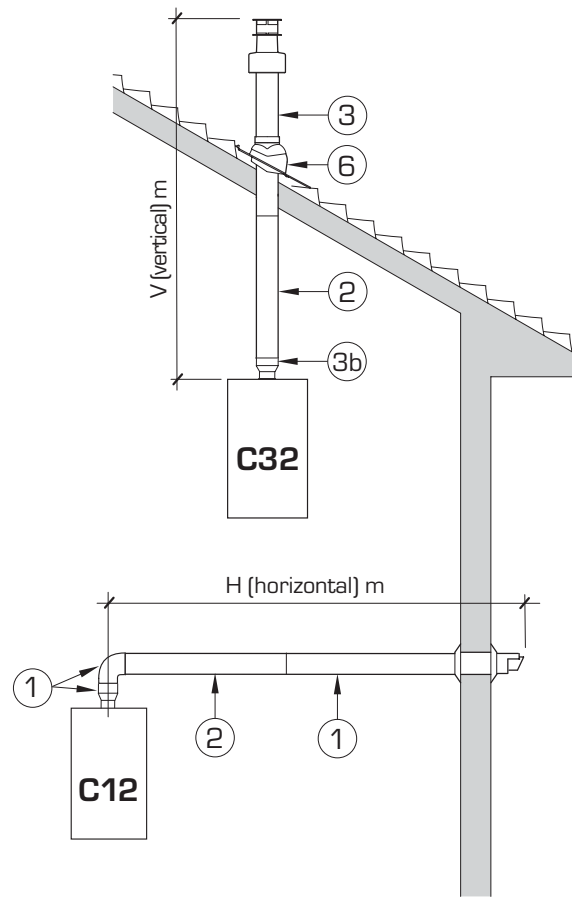

LIST OF ø 80/125 ACCESSORIES

- 1 Coaxial duct kit code 8096253
- 2 Extension L. 1000 code 8096171
- 2 Extension L. 500 code 8096170
- 3 Vertical terminal code 8091212A includes item 3b
- 3b Vertical adaptor code 8093150
- 6 Angled flashing plate code 8091300
 - 90° degree bend code 8095870
 - 45° degree bend code 8095970

Model	Length of pipe					
	ø 60/100 (m)		ø 80/125 (m)			
	H	V	H		V	
		Min.	Max.	Min.	Max.	
25 HE -EV	5,0	6,0	-	-	-	-
30 HE -EV	2,5	3,5	2,5	5,0	4,0	7,0
System 25 HE -EV	5,0	6,0	-	-	-	-
System 30 HE -EV	2,5	3,5	2,5	5,0	4,0	7,0

Fig. 5

MAXIMUM PERMITTED LENGTHS
KIT ø 60/00 PLUME CODE 8096260

NOTE: The use of the additional 90° curve (ø 60) supplied as standard reduces the available length (B) by 1 meter.
 The use of a 45° curve (ø 60), available on request, reduces the available length by 0.7 m.

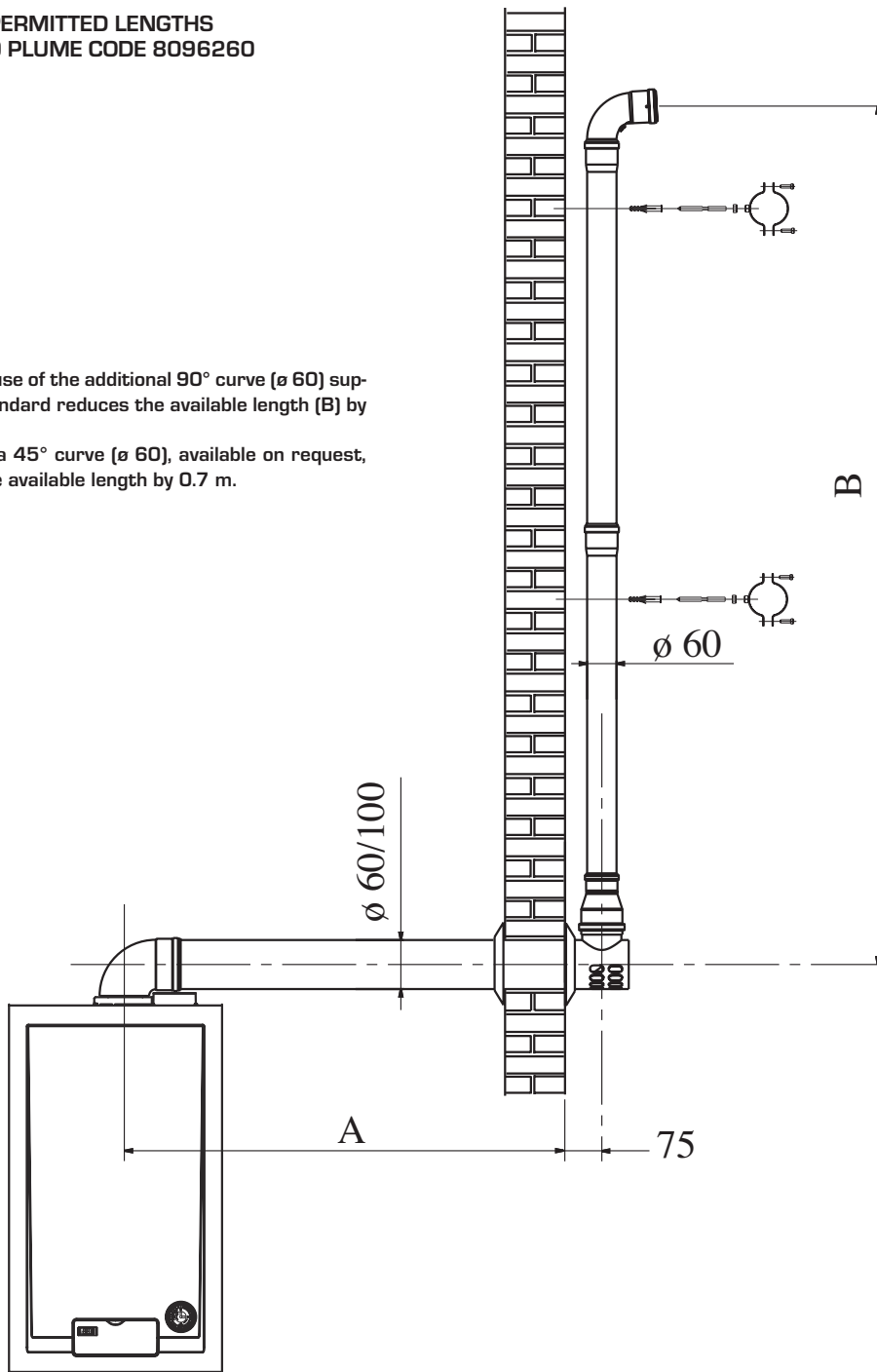

BOILER MODEL	A (Exhaust ø 60/100)		B (Flue ø 60)	
	Meters	No. of extensions L. 1000	Meters	No. of extensions L. 1000
ECOMFORT PLUS 25 HE -EV	0.90	-	3.9	4
ECOMFORT SYSTEM PLUS 25 HE -EV	1.90	1	2.9	3
ECOMFORT PLUS 30 HE -EV	0.90	-	2.0	2
	1.90	1	1.0	1

Fig. 5/a

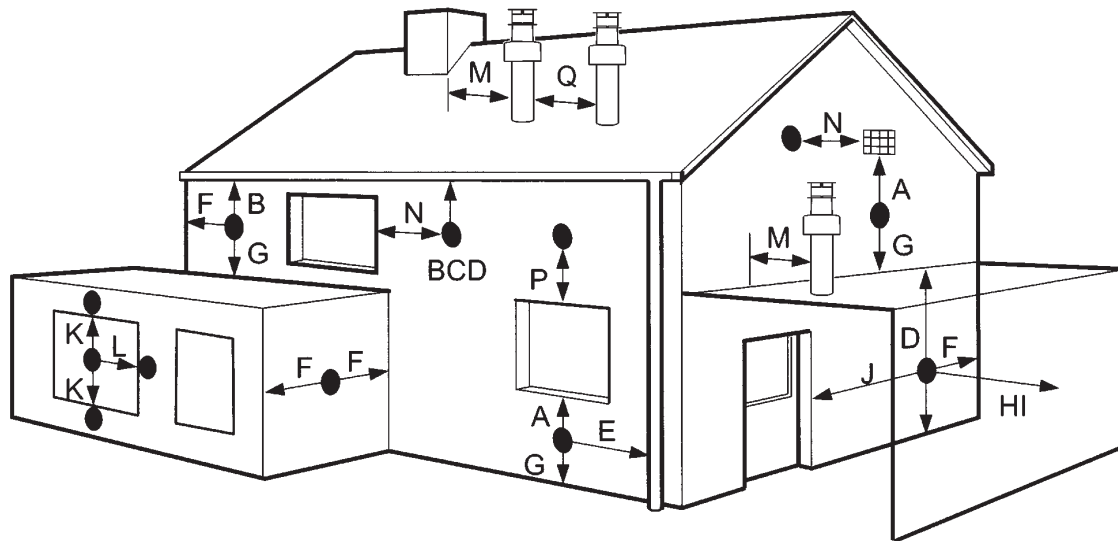

TABLE 4

Terminal position	Minimum spacing
A Directly below an openable window, air vent or any other ventilation opening	300 mm 12 in
B Below guttering, drain pipes or soil pipes [*]	75 mm 3 in
C/D Below eaves, balconies or carport roof	200 mm 8 in
E From vertical drain pipes or soil pipes	75 mm 3 in
F From internal or external corners	300 mm 12 in
G Above adjacent ground, roof or balcony level	300 mm 12 in
H From a boundary or surface facing the boiler	600 mm 24 in
I From a terminal facing the terminal	1,200 mm 48 in
J From an opening in the carport (eg door; window into dwelling)	1,200 mm 48 in
K Vertically from a terminal on the same wall	1,500 mm 60 in
L Horizontally from a terminal on the same wall	300 mm 12 in
M Horizontally from a vertical terminal to a wall	300 mm 12 in
N Horizontally from an openable window or other opening	300 mm 12 in
P Above an openable window or other opening	300 mm 12 in
Q From an adjacent vertical terminal	600 mm 24 in

[*] For condensing boilers this distance can be reduced to 25 mm without affecting boiler performance, but it will be necessary to protect the surfaces from the effects of condensate

- If the terminal discharges into a pathway or passageway check that combustion products will not cause nuisance and that the terminal will not obstruct the passageway.
- Where the lowest part of the terminal is fitted less than 2 m (78 in) above ground, above a balcony or above a flat roof to which people have access, the terminal MUST be protected by a purpose designed guard.
- Where the terminal is fitted within 850 mm (34 in) of a plastic or painted gutter; or 450 mm (18 in) of painted eaves, an aluminium shield at least 1,500 mm (59 in) long must be fitted to the underside of the painted surface.
- The air inlet/outlet flue duct MUST NOT be closer than 25 mm (1 in) to combustible material.
- In certain weather conditions the terminal may emit a plume of steam. This is normal but positions where this would cause a nuisance should be avoided.

Fig. 6

2.9 SEPARATE PIPES ø 80 (Optional alternative twin pipe system)

A special kit may be used to separate the flue gas outlet from the fresh air intake (fig. 7).

The maximum overall length of the intake and exhaust ducts depends on the head losses of the single fittings installed (excluding the doublers) and must not be

greater than 11.5 mm H₂O ("25 HE -EV" and "SYSTEM 25 HE -EV" models) and 8.0 mm H₂O ("30 HE -EV" model).

See Table 4 for information on the load losses of single accessories and the example of fig. 7 for information on how to calculate load losses.

NOTE: Ensure that any accessories are suitable for condensing boilers.

2.9.1 Separate pipe accessories

Kit code 8089912 is supplied for this purpose (fig. 8).

2.9.2 Separate ducts kit (fig. 8/a)

The diagrams of Figure 8/a show a couple of examples of the permitted exhausts configurations.

TABLE 5

Accessories ø 80	Head loss (mm H ₂ O)		Head loss (mm H ₂ O)	
	"25 HE -EV/SYSTEM 25 HE -EV"		"30 HE -EV"	
	Inlet	Outlet	Inlet	Outlet
90° elbow MF	0.25	0.35	0.30	0.40
45° elbow MF	0.15	0.25	0.20	0.30
Extension L. 1000 (horizontal)	0.20	0.25	0.20	0.30
Extension L. 1000 (vertical)	0.20	0.15	0.20	0.20
Terminal	0.10	0.35	0.10	0.40
Roof outlet terminal *	1.30	0.15	1.50	0.20

* This loss includes the losses of the adaptor 8091401

Example of allowable installation "25 HE -EV" calculation in that the sum of the head losses of the single fittings is less than 15.0 mm H₂O:

	Inlet	Outlet	
9 m horizontal pipe ø 80 x 0,20	1,80	-	
9 m horizontal pipe ø 80 x 0,25	-	2,25	
n° 2 90° elbows ø 80 x 0,25	0,50	-	
n° 2 90° elbows ø 80 x 0,35	-	0,70	
n° 1 terminal ø 80	0.10	0.35	
Total head loss	2,40	+ 3,30	= 5,7 mm H₂O

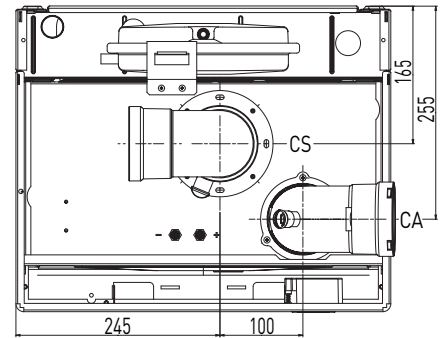
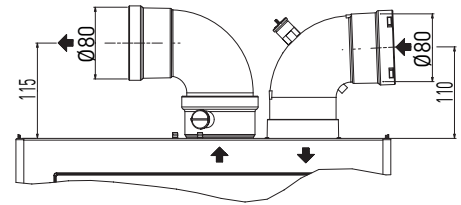

KEY
CA Inlet
CS Outlet

Fig. 7

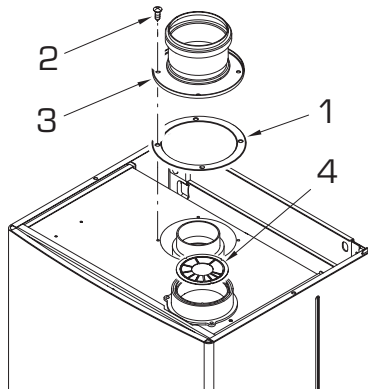

KEY
1 Gasket ø 125/95
2 Fixing screw
3 Flue outlet flange
4 Inlet air diaphragm

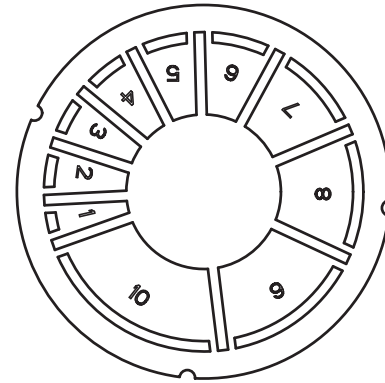

N° segments to remove	Total load loss mm H ₂ O
	"25 HE -EV/SYSTEM 25 HE -EV" models
-	0 ÷ 2,0
n° 1	2,0 ÷ 4,0
n° 1 e 2	4,0 ÷ 6,0
da n° 1 a 3	6,0 ÷ 7,0
da n° 1 a 4	7,0 ÷ 8,0
da n° 1 a 6	8,0 ÷ 9,0
da n° 1 a 8	9,0 ÷ 10,0
without diaphragm	10,0 ÷ 11,5

N° segments to remove	Total load loss mm H ₂ O
	"30 HE -EV" models
-	0 ÷ 1,0
n° 1 e 2	1,0 ÷ 2,0
da n° 1 a 3	2,0 ÷ 3,0
da n° 1 a 4	3,0 ÷ 4,0
da n° 1 a 6	4,0 ÷ 5,0
da n° 1 a 7	5,0 ÷ 6,0
da n° 1 a 8	6,0 ÷ 7,0
without diaphragm	7,0 ÷ 8,0

Fig. 8

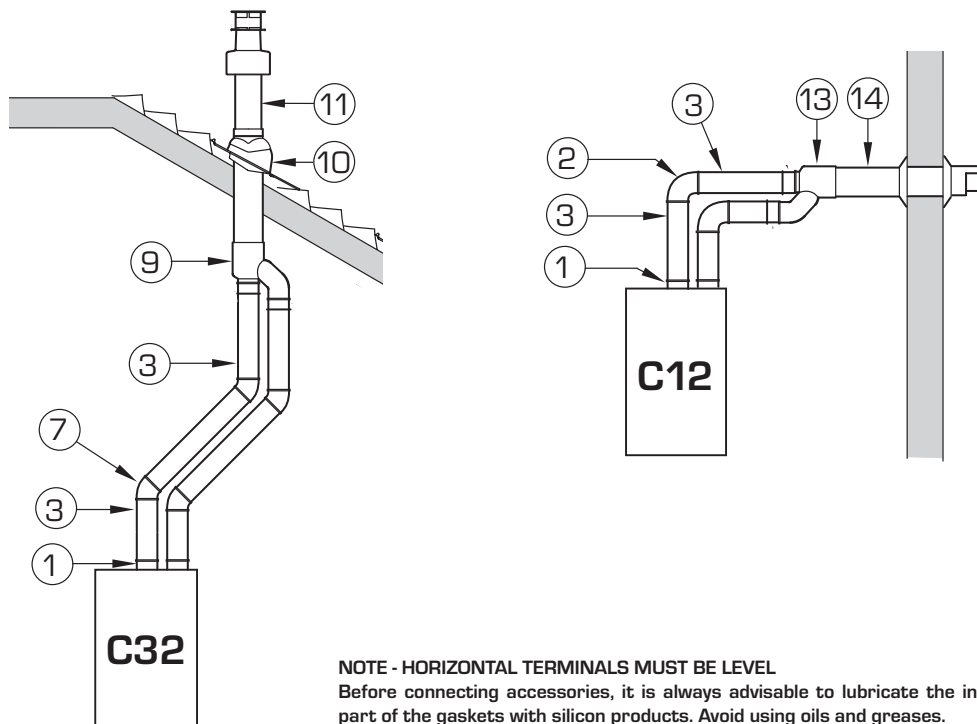

LIST OF ø 80 ACCESSORIES

- 1 Separate pipe accessories code 8089912
- 3 a Extension L. 1000 code 8077351 (6 pz.), 8077351A (single)
- 3 b Extension L. 500 code 8077350 (6 pz.), 8077350A (single)
- 7 a Additional 45° MF curve code 8077451(6 pz.), 8077450A(single)
- 7 b Additional 90° MF curve code 8077450 (6 pz.), 8077451A(single)
- 9 Manifold, code 8091401
- 10 Tile for joint code 8091300
- 11 Terminal for roof exit L. 1381 code 8091205
- 13 Union suction/ exhaust code 8091401
- 14 Coaxial exhaust ø 80/ 125 L. 885 code 8096253A

Fig. 8/a

2.10 ELECTRICAL CONNECTION

The boiler is supplied with an electric cable. Should this require replacement, it must be purchased exclusively from SIME.

The electric power supply to the boiler must be 230V - 50Hz single-phase through a 3 amp fused main switch, with at least 3 mm spacing between contacts.

Respect the L and N polarities and the earth connection.

NOTE: SIME declines all responsibility for injury or damage to persons, animals or property, resulting from the failure to provide for proper earthing of the appliance, or incorrect connection of external controls. Any fault or component failure due to incorrect connection of external controls is not covered in the warranty.

2.10.1 Climatic control option

The boiler is designed for connection to an external temperature sensor, supplied on request (code 8094101), which can automatically regulate the temperature value of the boiler output according to the external temperature.

For installation, follow the instruction in the package.

2.10.2 Use with different electronic systems

Some examples are given below of boiler systems combined with different electronic systems.

Where necessary, the parameters to be

set in the boiler are given.

For the electrical connections to the boiler refer to the diagrams (fig. 9 /9a).

Description of the letters indicating the components shown on the system diagrams 1 to 3:

- M C.H. flow
- R C.H. return
- SE External temperature sensor
- TA 1-2 Zone room thermostat
- VZ 1-2 Zone valve
- RL 1-2 Zone relay
- SI Hydraulic separator
- P 1-2 Zone pump
- IP Floor system
- VM Three-way mixer valve
- TSB Safety thermostat low temperature

1 BASIC SYSTEM

SYSTEM WITH SINGLE HEATING ZONE AND ROOM THERMOSTAT, OPTIONAL EXTERNAL SENSOR (Code 8094101)

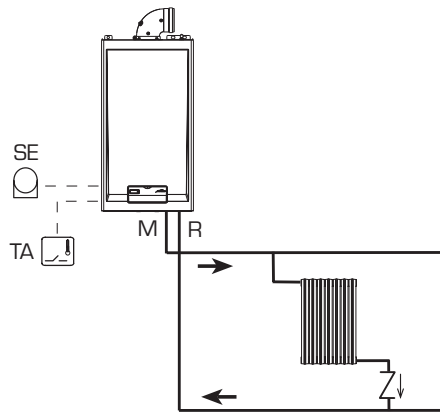

2 BASIC SYSTEM

MULTI-ZONE SYSTEM WITH VALVE, ROOM THERMOSTAT AND EXTERNAL SENSOR (Code 8094101)

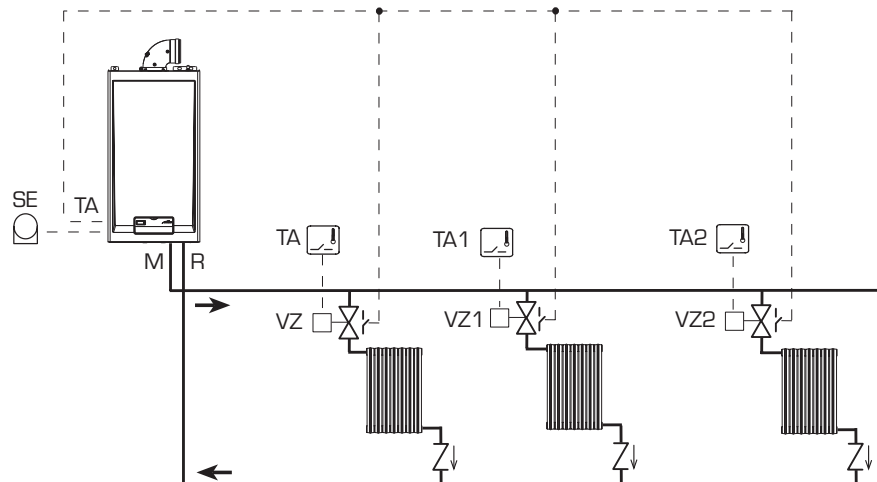

3 BASIC SYSTEM

MULTI-ZONE SYSTEM WITH PUMP, ROOM THERMOSTATS AND EXTERNAL SENSOR (Code 8094101)

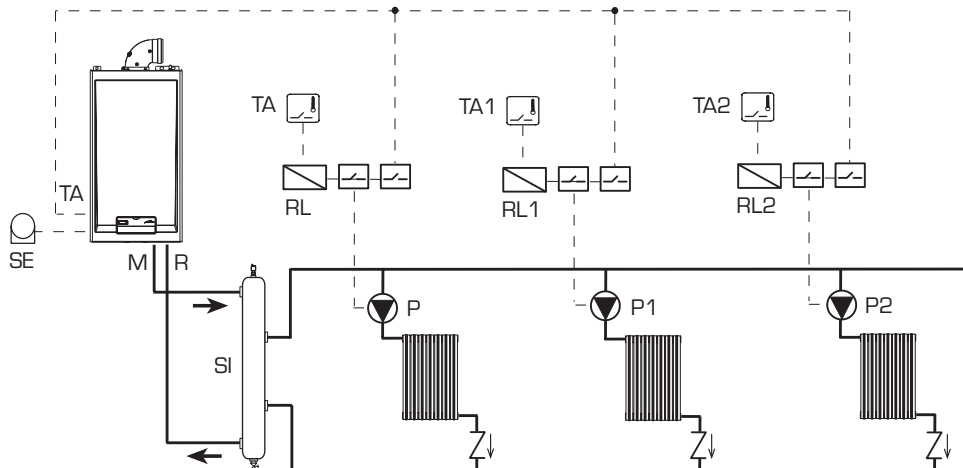

2.11 BOILER ELECTRICAL "ECOMFORT PLUS 25-30 HE -EV

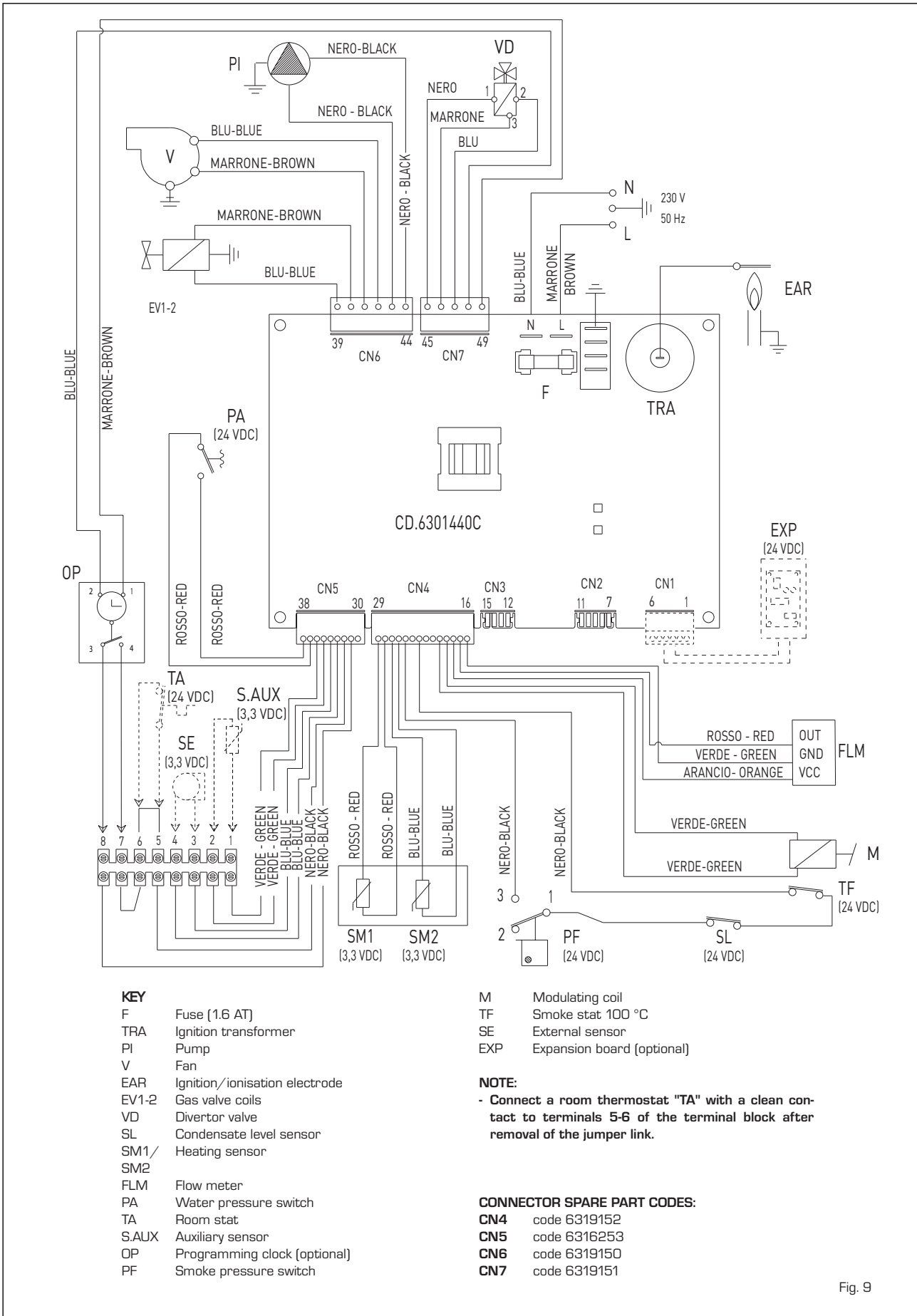

Fig. 9

2.12 BOILER ELECTRICAL "ECOMFORT SYSTEM PLUS 25 HE-EV"

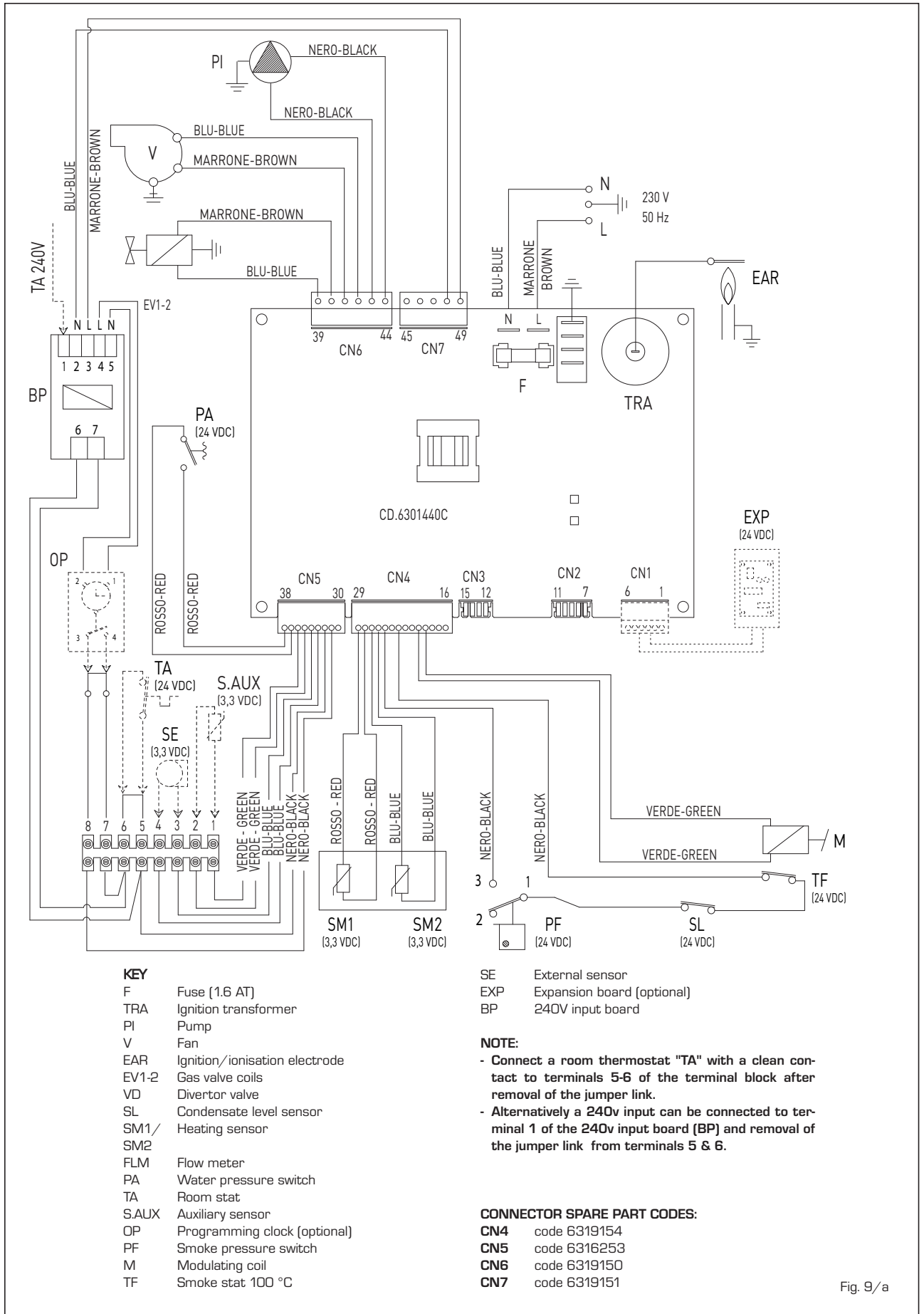
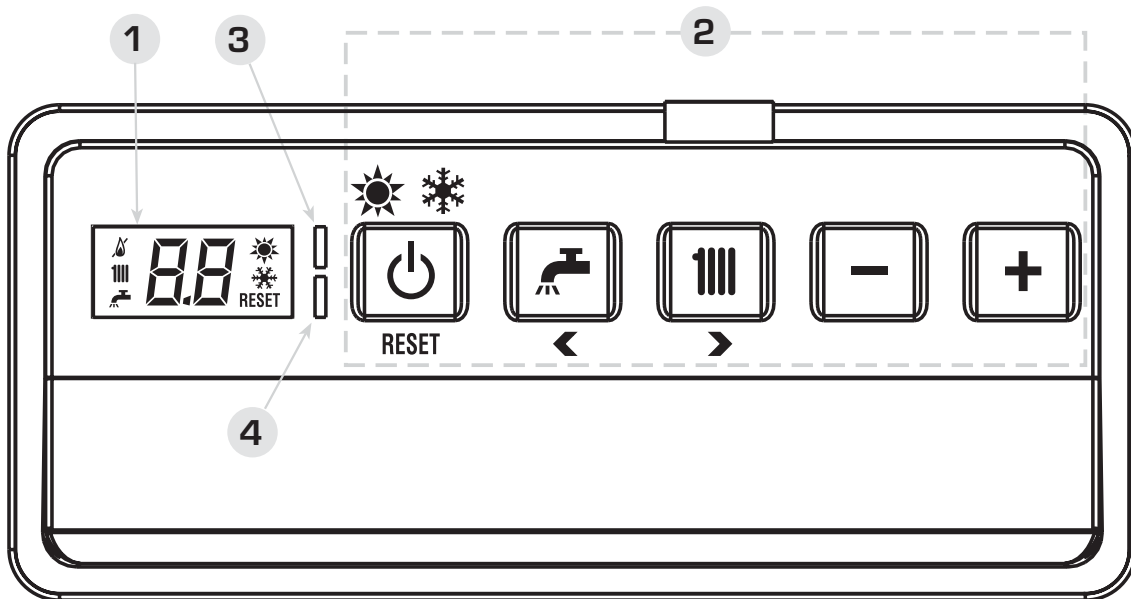









Fig. 9/a

3 CHARACTERISTICS





3.1 CONTROL PANEL



1 - DESCRIPTION OF DISPLAY ICONS

-  SUMMER MODE ICON
-  WINTER MODE ICON
-  D.H.W. MODE ICON
-  HEATING MODE ICON
-  BURNER LIT ICON
-  LOCKOUT DUE TO NO IGNITION/FLAME DETECTION
-  RESET REQUIRED
-  MAIN DIGITS

2 - DESCRIPTION OF CONTROLS

-  **OPERATING MODE/RESET**
Press this key repeatedly to step from standby to summer to winter. The green LED will flash to indicate a key has been pressed. Press and hold the key for more than two seconds to enter standby. RESET is only available if a resettable error is signalled
-  **D.H.W. SET**
Press the key to display the D.H.W. temperature set value.
-  **HEATING SET**
Press the key to display the heating temperature set value (value not relative to the remote control)
-  **DECREASE**
Pressing this key decreases the set value
-  **INCREASE**
Pressing this key increases the set value

3 - LED GREEN

ON = Indicates the presence of electrical voltage.
It can be disabled by setting **PAR 3 =0**
The green LED will flash and beep momentarily to indicate that a key press has been made and accepted..



4 - LED RED

OFF = Normal operation
ON = Boiler error signalled
Flashing when the control panel buttons are pressed inside the PARAMETERS SECTION.

ATTENTION: Use the keys to alter the value of any function, a beep indicates that the change was accepted. The display will remain lit for 15 minutes (PAR 5 default).



Fig. 10

3.2 ACCESS TO INSTALLER'S PARAMETERS

For access to the installer's parameters, press simultaneously the ( and ) keys for 5 seconds.

The red LED flashes and the display shows :





The parameters can be scrolled with  or .

To enter the parameter press **-** or **+**. The value set **flashes**, the display shows :



Proceed as follows to change the set value:

- set the new value using **-** or **+**.
- confirm the set value using  or .

Press  to exit the parameters section. The display is shown automatically after 5 minutes. The parameters section contains the alarms log, info and meters (display only).

3.2.1 Replacing the board or RESETTING parameters

If the electronic board is replaced or reset or the type of gas used is changed, it is necessary to configure PAR 01 and PAR 02 by associating the following values to each type of boiler to be able to restart the boiler:

BOILER	GAS	MODELS	PAR 1
ECOMFORT PLUS HE -EV	METHANE (G20)	25	01
		30	02
	LPG (G30/G31)	25	03
		30	04

BOILER	PAR 2
ECOMFORT PLUS 25-30 HE -EV	09
ECOMFORT PLUS SYSTEM 25 HE -EV	12

NOTE: the boiler panel has a label with the values that have to be set for PAR 01 and PAR 02 (fig. 17).

PARAMETERS INSTALLER

FAST CONFIGURATION					
PAR	DESCRIPTION	RANGE	UNIT OF MEASUREMENT	INC/DEC UNIT	DEFAULT SETTING
01	Combustion configuration	- = ND 1 ... 8	=	=	"."
02	Hydraulic configuration	- = ND 1 ... 22	=	=	"."
03	Disabling of the green LED	0 = Disabled 1 = Enabled	=	=	01
04	Correction of external probe values	-5 ... 05	°C	1	00
05	Default time of keypad locking	- = Disabled 1 ... 99	Min.	1	15
D.H.W. - HEATING					
PAR	DESCRIPTION	RANGE	UNIT OF MEASUREMENT	INC/DEC UNIT	DEFAULT SETTING
10	Frost protection temperature	0 ... 10	°C	1	03
11	External sensor antifreeze	- = Disabled - 9 ... 05	°C	1	- 2
12	Climatic curve setting	03 ... 40	=	1	20
13	Minimum heating temperature	40 ... PAR 14	°C	1	40
14	Maximum heating temperature	PAR 13 ... 80	°C	1	80
15	Maximum power heating	30 ... 99	%	1	99
16	Post-circulation time	0 ... 99	10 sec.	1	03
17	Pump heating activation delay	0 ... 99	10 sec.	1	01
18	Re-ignition delay	0 ... 10	Min.	1	03
19	Modulation D.H.W. flowmeter	- = Disabled 1 = Enabled	=	=	01
29	Anti-legionella (only D.H.W. tank)	- = Disabled 50 ... 80	°C	1	"."
PARAMETERS RE-SET					
PAR	DESCRIPTION	RANGE	UNIT OF MEASUREMENT	INC/DEC UNIT	DEFAULT SETTING
49 *	Reset default parameters (PAR 01 - PAR 02 equal "-")	- , 1	=	=	=
* To reset the circuit board to the default settings, set PAR49 to 1. PAR1 and PAR2 will need to be set as shown in 3.2.1					
ALARMS (visualization)					
PAR	DESCRIPTION	RANGE	UNIT OF MEASUREMENT	INC/DEC UNIT	DEFAULT SETTING
A0	Code of last error	=	=	=	=
A1	Code of last error -1	=	=	=	=
A2	Code of last error -2	=	=	=	=
A3	Code of last error -3	=	=	=	=
A4	Code of last error -4	=	=	=	=
A5	Code of last error -5	=	=	=	=
A6	Code of last error -6	=	=	=	=
A7	Code of last error -7	=	=	=	=
A8	Code of last error -8	=	=	=	=
A9	Code of last error -9	=	=	=	=
INFO (visualization)					
PAR	DESCRIPTION	RANGE	UNIT OF MEASUREMENT	INC/DEC UNIT	DEFAULT SETTING
i0	External sensor temperature	-9 ... 99	°C	1	=
i1	C.H. 1 sensor temperature	-9 ... 99	°C	1	=
i2	C.H. 2 sensor temperature	-9 ... 99	°C	1	=
i3	D.H.W. sensor temperature	-9 ... 99	°C	1	=
i4	Auxiliary sensor AUX temperature	-9 ... 99	°C	1	=
i5	Set of effective heating temperature	PAR 13 ... PAR 14	°C	1	=
i6	Level survey flame	00 ... 99	%	1	=
i7	Current to the modulator	00 ... 17	10 mA	1	=
i8	Flow rate D.H.W. flow meter	00 ... 99	l/min	1	=
COUNTERS (visualization)					
PAR	DESCRIPTION	RANGE	UNIT OF MEASUREMENT	INC/DEC UNIT	DEFAULT SETTING
c0	Number hours of operation of the burner	00 ... 99	h x 100	0,1 from 0,0 to 9,9 1 from 10 to 99	00
c1	Number of ignitions of the burner	00 ... 99	x 1000	0,1 from 0,0 to 9,9 1 from 10 to 99	00
c2	Total number of errors	00 ... 99	x 1	1	00
c3	Number of accesses of the installer parameters	00 ... 99	x 1	1	00
c4	Number of accesses to the OEM parameters	00 ... 99	x 1	1	00

3.3 EXTERNAL SENSOR

If there is an external sensor, the heating settings SET can be taken from the climatic curves according to the external temperature and, in any case, limited to with the range values described in point 3.2 (parameters PAR 13 and PAR 14).

The climatic curve to be set can be selected from a value of 3 and 40 (at step 1). Increasing the steepness of the curves of fig. 11 will increase the output temperature as the external temperature decreases.

3.4 BOARD FUNCTIONING

The electronic board has the following functions:

- Antifreeze protection of the heating circuits.
 - Ignition and flame detection system.
 - Control panel setting for the power and the gas for boiler functioning.
 - Anti-jamming for the pump which is fed for a few seconds (10") after 48 hours of inactivity.
 - Chimney sweep function which can be activated from the control panel.
 - Temperature which can be shifted with the external sensor connected.
 - Automatic regulation of the ignition power and maximum heating.
- Adjustments are managed automatically by the electronic card to guarantee maximum flexibility in use of the system.

3.5 TEMPERATURE DETECTION PROBE

Table 6 gives the values of the electrical resistance (Ω) obtained on the heating sensor according to the variations in temperature.

When the heating sensor (SM1/SM2) is interrupted, the boiler will not function.

TABLE 6

Temperature (°C)	Resistance (Ω)
20	12.090
30	8.313
40	5.828
50	4.161
60	3.021
70	2.229
80	1.669

3.6 ELECTRONIC IGNITION

Ignition and flame detection is controlled by a single electrode on the burner which guarantees reaction in the case of accidental extinction or lack of gas within one second.

3.6.1 Functioning cycle

Burner ignition should occur within 10 seconds of the opening of the gas valve. If after three attempts the ignition is not

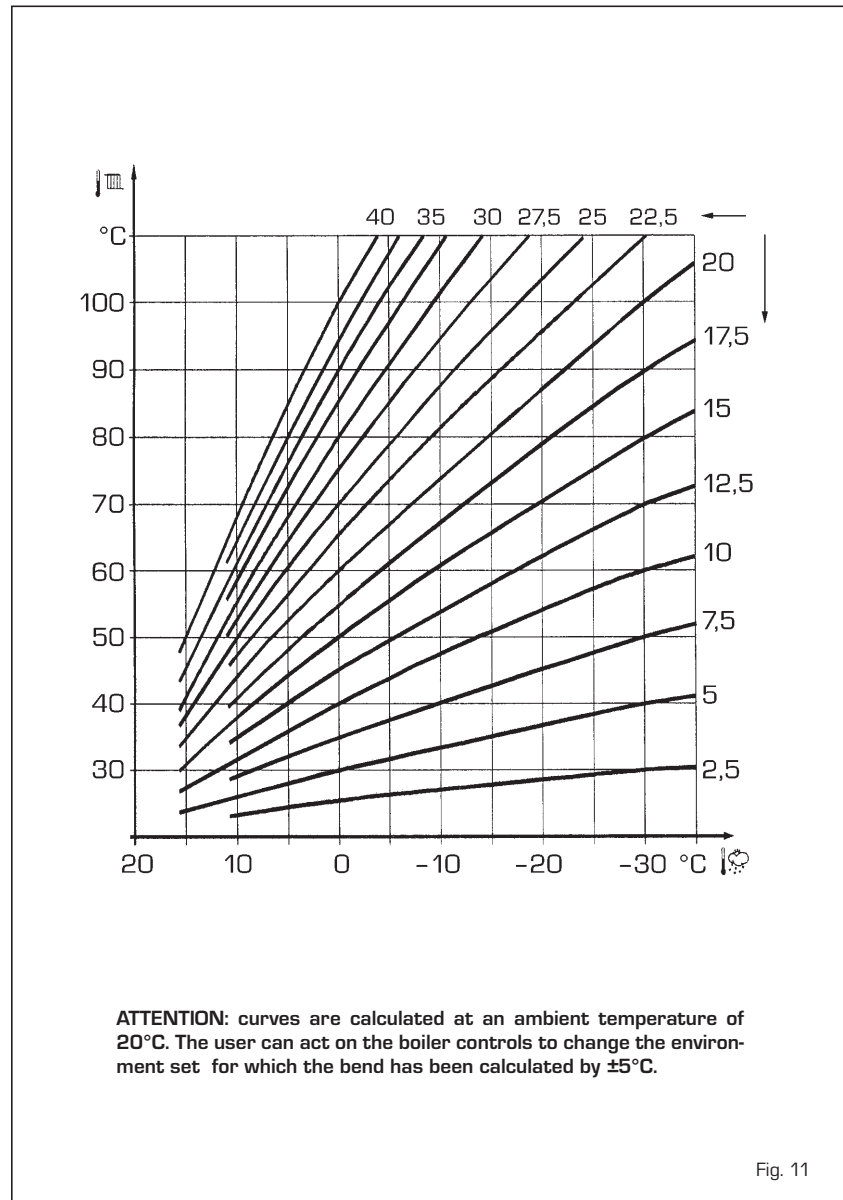

Fig. 11

detected the boiler will lockout (ALL 06):

- Lack of gas

The ignition electrode will discharge for a maximum of 10 seconds. If after three attempts the ignition is not detected the boiler will lockout (ALL 06). This can happen the first time a boiler is switched on, or after long periods of inactivity. It can also be caused by a closed gas cock or a gas valve not operating.

- No ionisation

The boiler will spark for 10 seconds, if after 3 attempts the ionisation is not detected, the boiler will lockout (ALL 06). This could be due to a poor connection or break in the ionisation cable. Check also that the cable is not shorted, badly worn or distorted.

In the case of a sudden loss of voltage, the burner will immediately switch off. When the voltage is restored, the boiler will auto-

matically start up again.

3.7 AIR PRESSURE SWITCH

The pressure switch is calibrated by the manufacturer at the following values:
0.62 - 0.72 H₂O for vers. "25 HE - EV/SYSTEM 25 HE -EV"
0.45 - 0.55 H₂O for vers. "30 HE -EV", which can guarantee boiler functioning provided that the inlet and exhaust pipe is within the maximum length allowed.

3.8 HEAD AVAILABLE TO SYSTEM

Residual head for the heating system is shown as a function of rate of flow in the graph in fig. 12.

To obtain the maximum head available to the system, turn off the by-pass by turning the union to the vertical position (fig. 13).

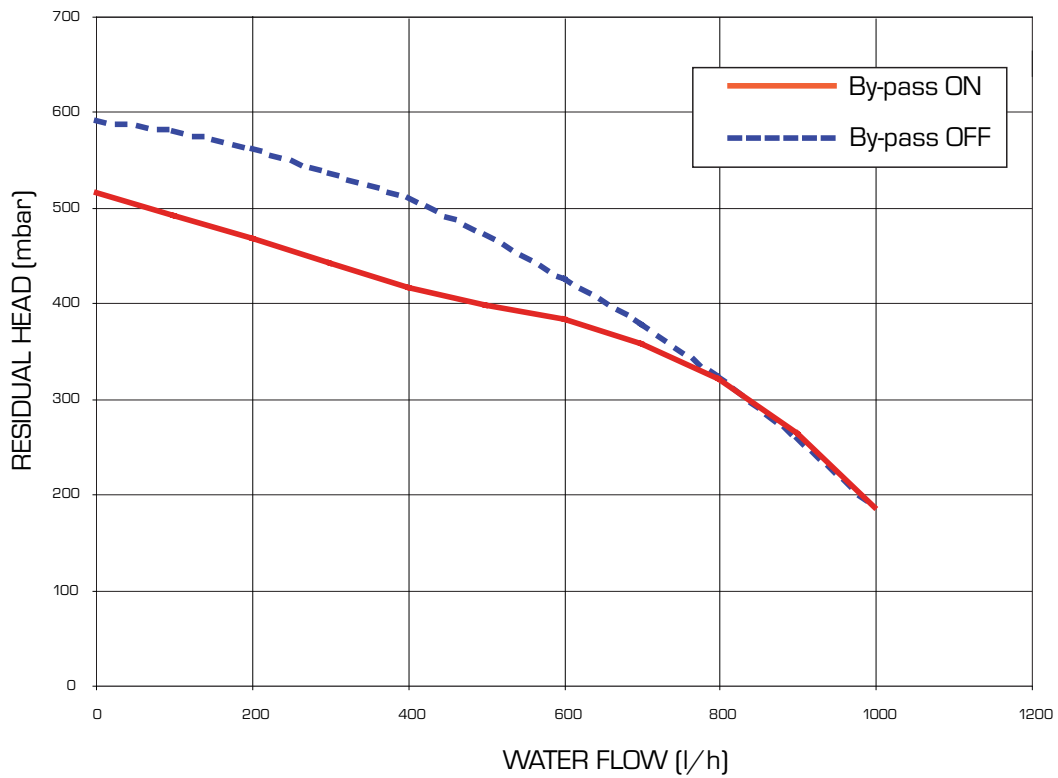

By pass OFF

Water flow (l/h)	0	100	200	300	400	500	600	700	800	900	1000
Residual head (mbar)	590	579	561	534	509	471	425	376	321	257	183

By pass ON

Water flow (l/h)	0	100	200	300	400	500	600	700	800	900	1000
Residual head (mbar)	514	490	467	441	415	396	382	357	319	262	185

Fig. 12

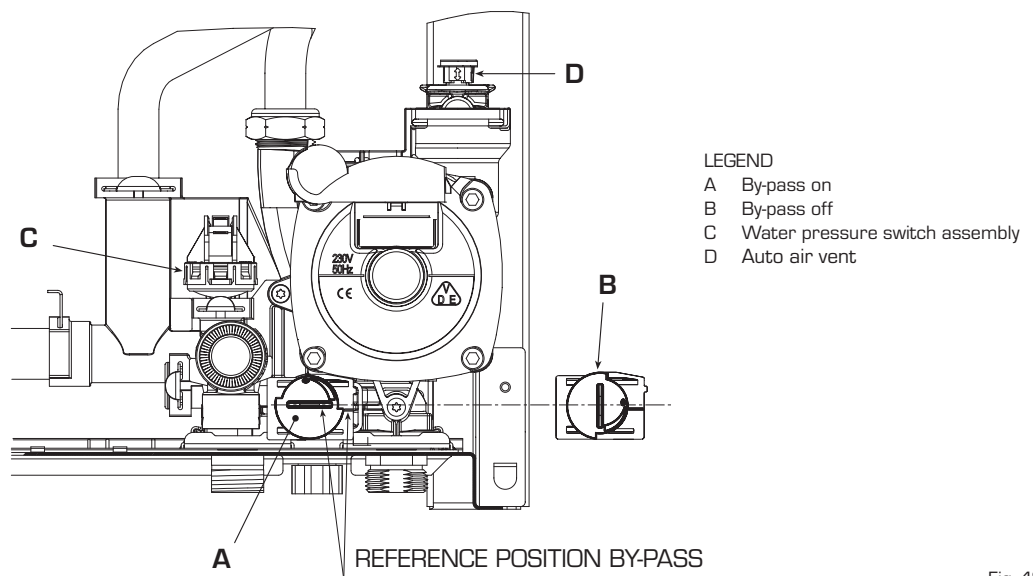

Fig. 13

4 USE, MAINTENANCE (including BENCHMARK) AND COMMISSIONING

4.1 GAS VALVE (fig. 14)

The boilers are equipped standard with the SIT 845 SIGMA gas valve (fig. 14).

The gas valve is set at two pressure values: maximum and minimum.

According to the type of gas being supplied, these correspond to the values given in Table 7.

The gas pressures at the maximum and minimum values, are factory and should not require adjustment.

Only a conversion to another gas (natural gas to LPG) should the gas valve be adjusted.

4.2 GAS CONVERSION (fig. 15)



This operation must be performed by authorised personnel using original Sime components.

To convert, perform the following operations (fig. 15):

- Close the gas cock, and isolate the boilers electrical supply
- Disassemble the burner manifold (3).
- Replace the main nozzles (6) supplied in a kit, inserting the copper washer (4). Use a $\varnothing 7$ spanner to perform this operation.
- Configure the new fuel as indicated in point 4.2.1
- For calibrating the maximum and minimum gas pressure values, see point 4.2.2.
- Fix the label to the data plate showing the new gas configuration.





NOTE: Ensure that on reassembly all seals are replaced as required, and the tightness tested, using a suitable leak detection fluid.

4.2.1 New fuel configuration

Access the parameters section by pressing the control panel keys ( and ) at the same time for 5 seconds.

The red LED flashes and the display shows:



Scroll the parameters using  or  . To enter the fuel configuration parameter PAR 01, use  or  .

The set value **flashes** and if the boiler in question is a **30 HE -EV** with methane, the display shows:

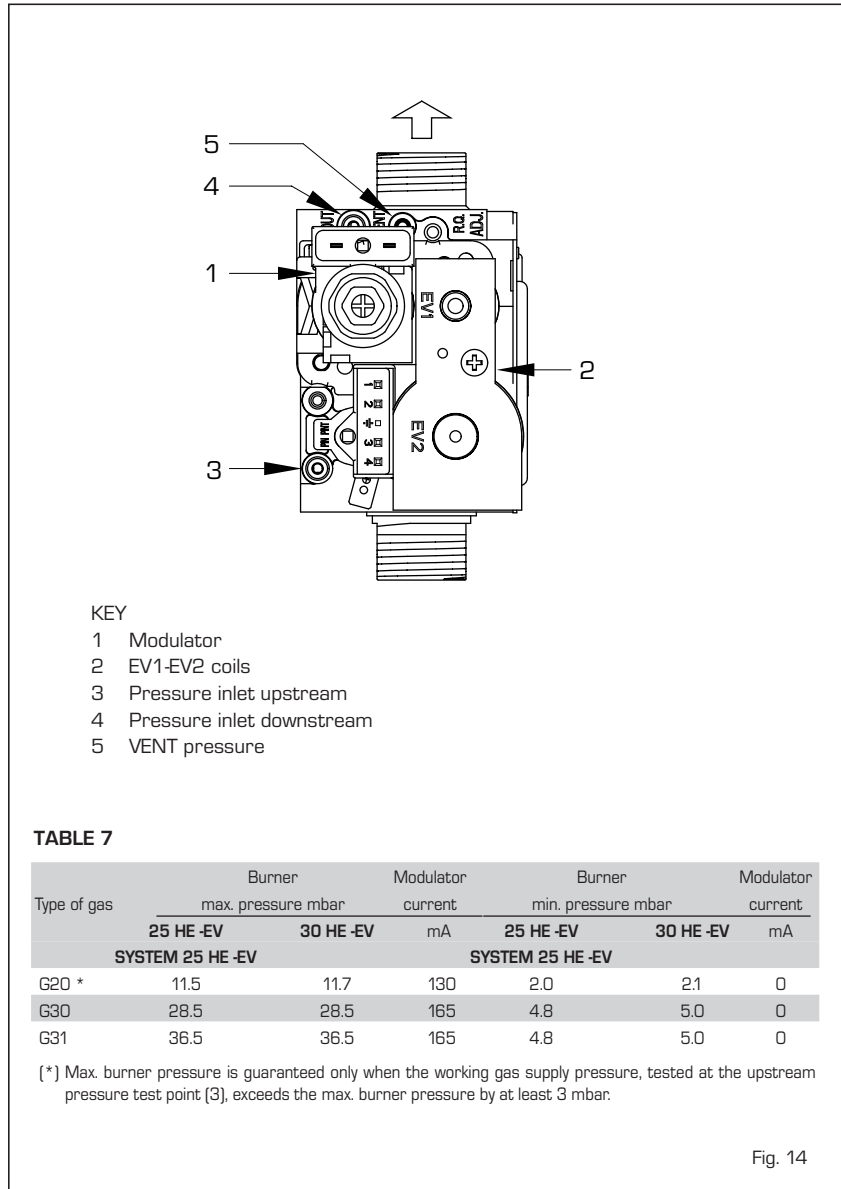

Fig. 14

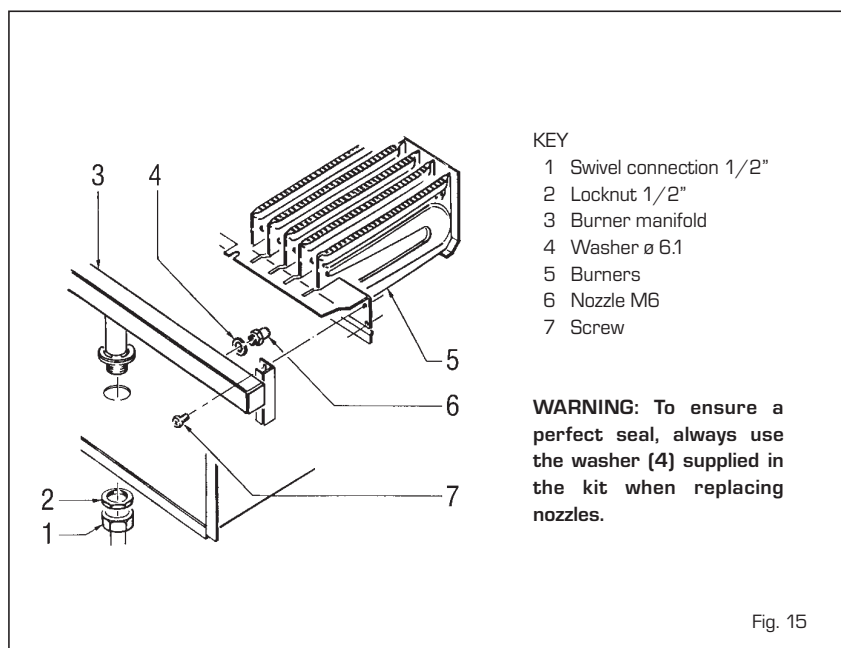

Fig. 15

or the **30 HE -EV** boiler to function with LPG, press **+** until **04** appears. Confirm this value using **↔** or **||||**. Exit the parameters section by pressing **⏻**. The table below gives the values to set when the supply gas is changed:

BOILER	GAS	MODELS	PAR 1
ECOMFORT PLUS HE -EV	METHANE (G20)	25	01
		30	02
	LPG (G30/G31)	25	03
		30	04

4.2.2 Adjusting the gas valve pressure (fig. 16)

Set maximum and minimum pressure on gas valves as follows (fig. 16):

- Connect a manometer to the intake downstream of the gas valve (4 fig. 14).
- **Disconnect the valve VENT pressure test point tube (5 fig. 14).**
- Remove the cap (1) from the modulator.
- Put the boiler in chimney sweep mode (see 4.4.1), completely open the hot water tap.
- Press the key **+** (Hi).
- Turning the gas valve adjusters clockwise will increase the pressure, anti-clockwise will decrease it.
- Adjust maximum pressure using the nut (3) with a wrench to the maximum pressure value indicated in **Table 7** (fig. 14).
- Adjust the maximum pressure before adjusting the minimum.
- Press the key **-** (Lo) while the hot water tap is on, with the water running.
- Hold the nut (3) in place, turn the screw (2) to the minimum pressure indicated in **Table 7** (fig. 14).
- Alternately press the keys **(- and +)** while keeping the hot sanitary water running all the time, and check that the maximum and minimum pressures correspond to the set values; if necessary readjust..
- Press the key **⏻** again to quit the function.
- Refit the valve VENT pipe.
- Remove the manometer, remembering to tighten the screw closing the pressure test point.
- Put the plastic cap (1) back on the modulator. Check all test points and connections for gas tightness.

4.3 DISMANTLING THE CASING (fig. 17)

The casing may be removed completely to facilitate boiler maintenance, as shown in fig. 17. Turn the panel control forward for access to the internal components of the boiler.

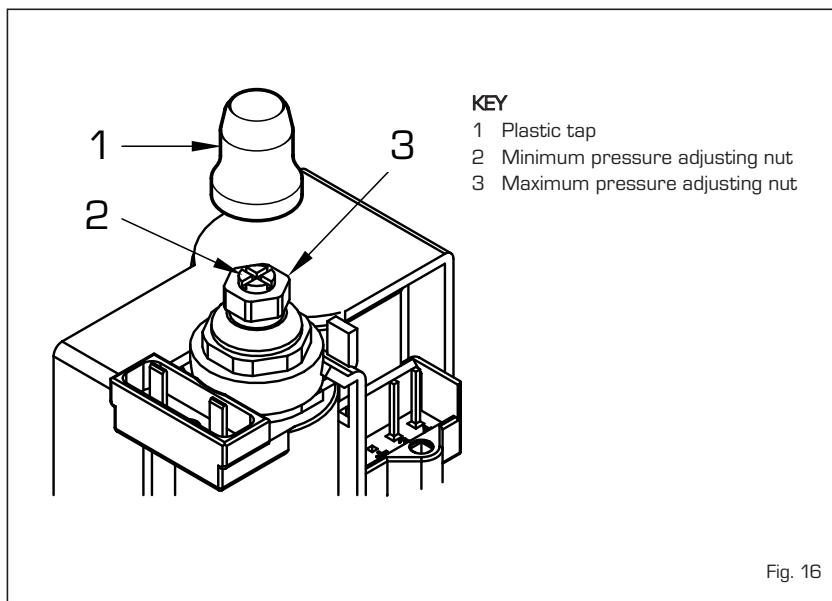

Fig. 16

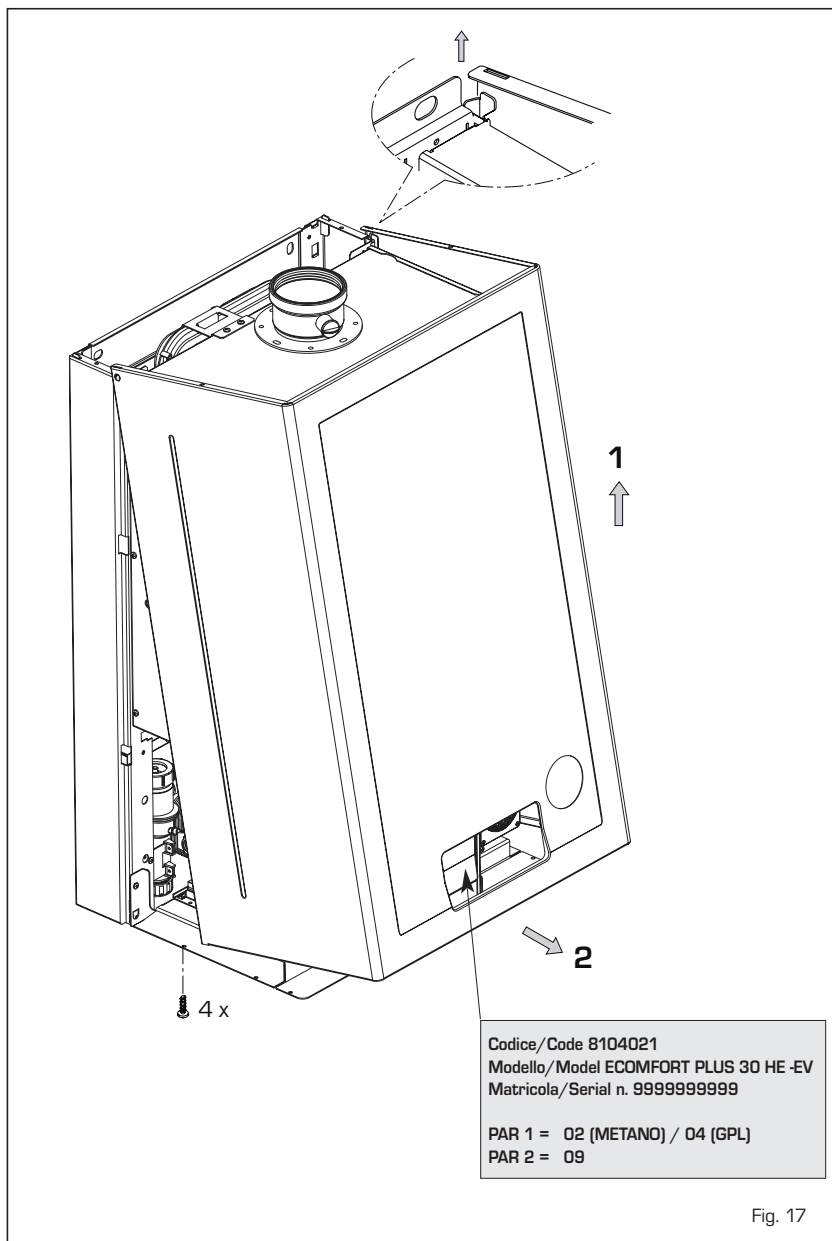

Fig. 17

4.4 MAINTENANCE

To guarantee the operation and efficiency of the appliance and to conform to the requirements of any extended warranty, it must be serviced regularly.

This should be at least annually and can only be done by a Gas Safe Registered engineer.

Carry out the cleaning of the heat exchanger in the following way:

- isolate the power supply and turn off the gas isolation valve.
- Remove the outer casing and the gas burner manifold unit. Ideally use a vacuum cleaner and a soft brush, so as to remove any dust particles that may have accumulated, take care not to damage the insulation.
- Clean the heat exchanger, removing any dust or residue from combustion. When cleaning the heat exchanger or the burners, chemical products or steel brushes **MUST NOT BE USED**. Make sure that the tops of the burners with the holes are free from encrustations.
- Reassemble the items removed from the boiler, making sure to follow the correct sequence.
- Check operation of the main burner.
- After assembly of all the gas connections, these must be tested for tightness using or appropriate products. **DO NOT USE NAKED FLAMES.**

4.4.1 Chimney sweep function

To check the gas valve pressures, connect a digital manometer to the downstream pressure test point item 4 fig 14, press at the same time the installer's key (- e +) for a few seconds.

The chimney sweep function will switch on , the boiler will ignite, and will continue for 15 minutes.

During the 15 minutes functioning of chimney sweep function, pressing the keys (- and +) take the boiler respective at maximum (Hi) and at minimum (Lo) power. Compare the values to those shown in table 7. During the chimney sweep operation the boiler will cut off at 80°C and re-ignition at 70°C.

Before activating the chimney sweep function make sure that the radiator valves and/or zone valves are open.

The test can also be carried out with the boiler working in D.H.W. mode.

To this, after activating the chimney sweep function, open one or more hot water taps. Under these conditions, the boiler will function at maximum power with the D.H.W. kept at between 60°C and 50°C.

During the test, the hot water faucets must remain open.

To exit to the chimney sweep function press the key ⏻ of the control panel.

The chimney sweep function will automa-

tically switch off after 15 minutes from the activation.

4.5 FUNCTIONING ERRORS

When there is a functioning error, an alarm appears on the display **and switch on the red led.**

Descriptions of the errors with relative alarms and solutions are given below:

- ALARM 01 (fig. 18)

The display shows "AL 01".

It can be caused by:

- a) The smoke stat has intervened;
- b) Fan failure;
- c) The air pressure switch has intervened;
- d) The condensate level sensor has intervened.
- e) Confirm that PAR 1 is set correctly.

The boiler stops for an enforced period of 10 minutes.

At the end of this period, the boiler re-attempts ignition.

If the error is repeated three times in 24 hours, the boiler locks out.

Press the key ⏻ of the controls to start up the boiler again.

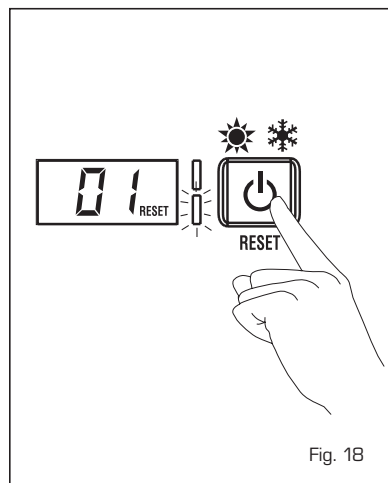

Fig. 18

- LOW WATER PRESSURE ERROR ALARM 02 (fig. 18/a)

If the system pressure detected by the water pressure switch is lower than 0.5 bar, the boiler stops and the display shows the alarm "AL 02".

Using the external filling loop, increase the pressure indicated on the pressure gauge to between 1 and 1.2 bar.

WHEN FILLING HAS BEEN COMPLETED, ENSURE THAT THE FILLING LOOP IS TURNED OFF AND THE HOSE DISCONNECTED.

If the refilling procedure has to be repeated several times, it is advisable to check that the heating circuit is intact [check that there are no leaks].

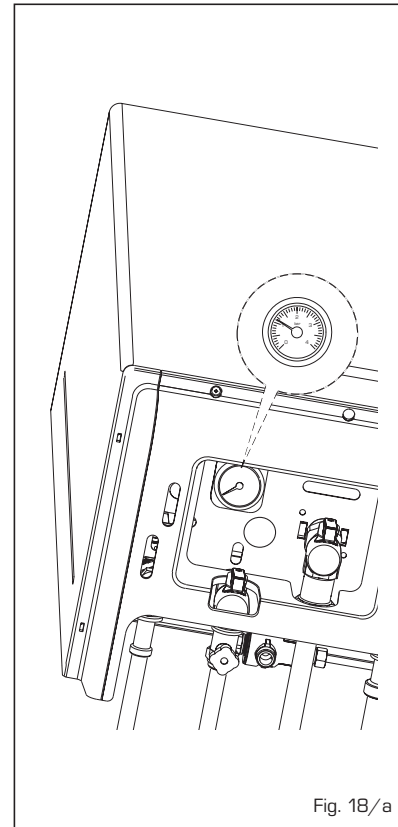

Fig. 18/a

- ALARM 04

Confirm that PAR 2 is set correctly.

- HEATING SENSOR ERROR ALARM 05

If one or both sensing elements of heating sensor (SM1/SM2) are open or short circuited, the boiler will not function and the display will show the alarm "AL 05".

- LOCKOUT ALARM 06 (fig. 18/b)

If the flame control has not detected the presence of the flame after a complete ignition sequence, or for any other reason the card cannot "see" the flame, the boiler will stop and the display will show the alarm "AL 06".

Press the key ⏻ of the controls to start up the boiler again.

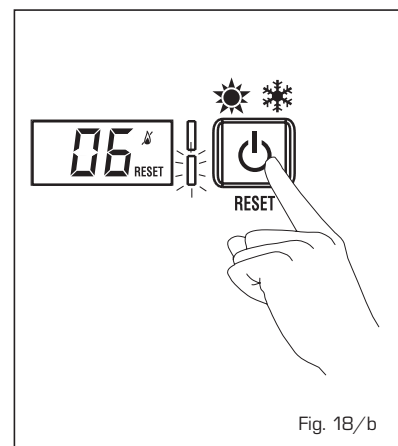

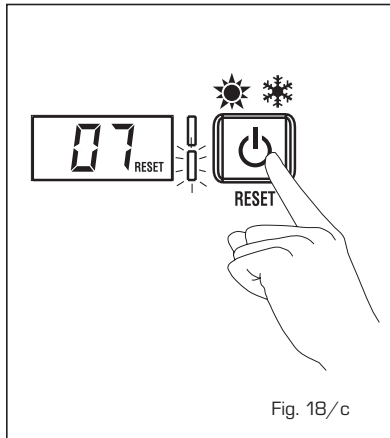

Fig. 18/b

- **SAFETY THERMOSTAT ERROR
ALARM 07 (fig. 18/c)**

If the C.H. sensor (SM1/SM2) exceeds the 100°C the boiler will not ignite, the display shows AL07 and the green LED will stay lit. If the error persists for more than one minute, the boiler will stop and the red LED will illuminate. Press the key  of the controls to start up the boiler again.



- **FLAME DETECTION ERROR
ALARM 08**

If a flame is detected when one should not be present; the boiler will stop and the display will show anomaly "AL 08".

- **AUXILIARY SENSOR ERROR
ALARM 10**

This error is not applicable to UK boilers, check the setting of PAR 2.

- **MODULATOR ERROR ALARM 11**

If the gas valve modulator coil becomes disconnected or open circuit the display will show "AL 11".

The boiler will function at minimum power.

- **HEATING PROBE POSITIONING
ERROR SM1/SM2 "AL 16" (fig. 18/d)**

If the heating probe sensor does not detect a temperature rise within 10 seconds after a burner ignition, the burner will switch off, the display will show AL16 and the green LED will stay lit. If the error occurs three times within a 24hr period, the boiler will lockout, the display continues to show AL16 and the red LED illuminates. Press  on the control panel to restart the boiler.

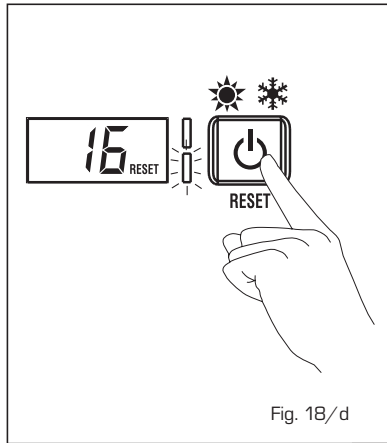

- **SENSOR ERROR "AL 17"**

When the two sensitive elements of the heating probe (SM1/SM2) differ to each other by more than 16°C the boiler does not operate and the display shows error AL 17.

Replace the heating probe (SM1/SM2) to restore operation.

**4.6 COMMISSIONING AND
ROUTINE SERVICE**

Commissioning and servicing can only be done by a qualified engineer.

4.6.1 Commissioning

PLEASE NOTE: The gas valve for this appliance has been checked, adjusted and preset at the factory for operation on the gas type defined on the appliance data plate.

However it is advisable to check that the gas valve is set correctly having first checked:

- That the boiler has been installed in accordance with these instructions.
- The integrity of the flue system and the flue seals.
- The integrity of the boiler combustion circuit and all the relevant seals.

The following procedure should be done after installation a gas purge and tightness/drop test have been made.

Ensure that the auto air vent (13 fig. 3) is opened, turn the electrical supply on.

With the boiler on standby fill the system and pressurise to 1.5 bar (fig. 18/a).

Ensure that the pump has been manually rotated.

Open the gas cock, press the "❄ mode key" (fig. 10).

Check the operational (working) gas inlet pressure.

Set up the boiler to operate at maximum rate as described in 4.4.1 (Chimney sweep)].

With the boiler operating in the maximum

rate condition check that the operational (working) gas pressure at the inlet test point (see fig 14 item 3) is 21 mb +/- 2 mb.

Ensure that this inlet pressure can be obtained with all other gas appliances in the property working.

Check the setting of the gas valve, using the procedure described in 4.2.2. and compare the values to those shown in table 3. Press "❄ mode key" (fig. 10).

Turn on a DHW tap fully (preferably the bath tap), ensure that the boiler ignites.

Set the controls to the required values as shown in the user guide.

Complete the Benchmark sheet enclosed in this manual.

Explain controls and operation to the user.

Leave all documentation with the user.

Ensure that the boiler is registered with gas Safe Register and Sime Ltd within 30 days of installation, and request that the owner records the registration number in the Benchmark checklist.

4.7 ROUTINE SERVICE

To comply with the conditions of any extended warranty offered and to ensure continued safe and efficient operation, the boiler must be serviced at regular intervals at least once a year.

It is the law that a Gas Safe Register registered engineer, must carry out any service work.

4.7.1 Check / Clean Filter (fig. 19)

The filter is located within the connection of the heat exchanger outlet pipe and the DHW hydraulic assembly. Fig 19.

To check or clean the filter; turn off the gas and electrical supplies to the boiler.

Close the flow and return isolation valves and drain the boiler.

Protect the internal components of the boiler from accidental water spillage, then

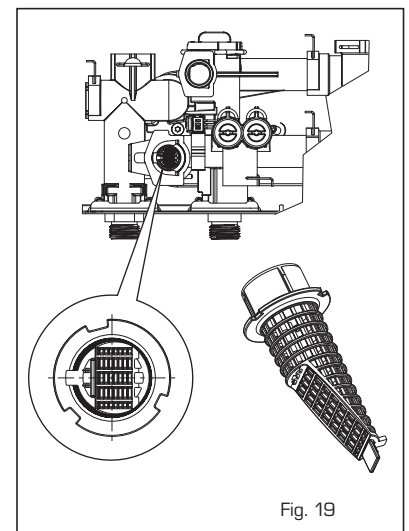

disconnect the heat exchanger outlet pipe from the hydraulic assembly.

Using pliers remove the filter. Clean it as required.

Refit in reverse order.

4.7.2 Burner inspection

- Access the burner as described in 6.3.
Using a soft brush, clean the burner of debris.

4.7.3 Combustion Chamber

Remove any loose debris from the combustion chamber using a soft brush and a vacuum cleaner.

Take care not to damage the rear insulation panel.

4.7.4 Condensate Trap

The condensate trap would not normally require removal during service, but can be checked, by carefully pouring water into the inner flue. Great care must be taken to avoid water entering the outer flue.

Check that the water flows freely to the drain.

Should it require removal, firstly disconnect the level sensor; then remove the clip securing the condensate drain pipe. Remove the condensate trap from its fixing bracket.

Clean and refit in reverse order.

Ensure that the trap is filled before allowing the boiler to operate.

4.7.5 Gas pressure test

Check the gas pressures as described in 4.2.2.

Service Record

It is recommended that your heating system is serviced regularly and that the appropriate Service Interval Record is completed. This is also a condition of any extended warranty offered.

Service Provider

Before completing the appropriate Service Record below, please ensure you have carried out the service as described in the manufacturer's instructions.

Always use the manufacturer's specified spare part when replacing controls.

Service 1 Date: _____
Engineer Name: _____
Company Name: _____
Telephone No. _____
Gas Safe Register No. _____
Comments: _____
Signature: _____

Service 2 Date: _____
Engineer Name: _____
Company Name: _____
Telephone No. _____
Gas Safe Register No. _____
Comments: _____
Signature: _____

Service 3 Date: _____
Engineer Name: _____
Company Name: _____
Telephone No. _____
Gas Safe Register No. _____
Comments: _____
Signature: _____

Service 4 Date: _____
Engineer Name: _____
Company Name: _____
Telephone No. _____
Gas Safe Register No. _____
Comments: _____
Signature: _____

Service 5 Date: _____
Engineer Name: _____
Company Name: _____
Telephone No. _____
Gas Safe Register No. _____
Comments: _____
Signature: _____

Service 6 Date: _____
Engineer Name: _____
Company Name: _____
Telephone No. _____
Operative ID No. _____
Comments: _____
Signature: _____

Service 7 Date: _____
Engineer Name: _____
Company Name: _____
Telephone No. _____
Gas Safe Register No. _____
Comments: _____
Signature: _____

Service 8 Date: _____
Engineer Name: _____
Company Name: _____
Telephone No. _____
Gas Safe Register No. _____
Comments: _____
Signature: _____

Service 9 Date: _____
Engineer Name: _____
Company Name: _____
Telephone No. _____
Gas Safe Register No. _____
Comments: _____
Signature: _____

Service 10 Date: _____
Engineer Name: _____
Company Name: _____
Telephone No. _____
Gas Safe Register No. _____
Comments: _____
Signature: _____

5 FAULT FINDING

If an electrical fault occurs on the appliance the preliminary electrical system checks must be carried out first.

When any service or replacement of electrical components which has required the breaking and re-making of electrical connections has taken place, the following tests must be repeated:

- earth continuity;
- short circuit;
- polarity;
- resistance to earth.

5.1 EARTH CONTINUITY CHECK

Appliances must be electrically disconnected, meter set on Ω (ohm) x 1 scale and adjust zero if necessary. Test leads from any appliance earth point (e.g. inside control box) see wiring diagrams (section 7) to earth pin on plug.

Resistance should be less than 1 Ω (ohm). If the resistance is greater than 1 Ω (ohm) check all earth wires for continuity and all contacts are clean and tight. If the resistance to earth is still greater than 1 Ω (ohm) then this should be investigated further.

5.2 SHORT CIRCUIT CHECK

Switches turned FULL ON - meter set on Ω (ohms) x 1 scale. Test leads from L to N on appliance terminal block, if meter reads 0 then there is a short circuit.

Meter set on Ω (ohm) x 100 scale. Repeat it with leads from L to E. If meter reads less than infinity (∞) there is a fault.

NOTE: Should it be found that the fuse has failed but no fault is indicated, a detailed continuity check (i.e. by disconnecting and checking each component) is required to trace the faulty component.

It is possible that a fault could occur as a result of local burning/arcing but no fault could be found under test. However, a detailed visual inspection should reveal evidence of burning around the fault.

5.3 POLARITY CHECK

Appliance reconnected to mains supply and meter set on 300 V ac scale. Test at appliance terminal block.

- Test leads from L to N meter reads

approx.: 240 V ac.

- Test leads from L to E " * " meter reads approx. 240 V ac.
- Test leads from N to E " * " meter reads from 0 to 15 V ac.

5.4 RESISTANCE TO EARTH CHECK

Appliance must be disconnected from main supply and meter on Ω (ohm) x 100 scale.

All switches including thermostat on test leads from L to E - if meter reads other than infinity (∞) there is a fault which should be isolated.

A detailed continuity check is required to trace the faulty component.

IMPORTANT:

These series of checks are the first electrical checks to be carried out during a fault finding procedure. On completion of the service/fault finding task which has required the breaking and remaking of electrical connections then the checks 5.1 Earth continuity, 5.3 Polarity and 5.4 Resistance to earth must be repeated.

6 REPLACEMENT OF PARTS

Note: Use silicone grease to ease the fitting of any push fit connections.

6.1 Expansion Vessel

- Isolate power supply
- Remove boiler cover
- Isolate flow and return valves
- Drain boiler using fitted drain vent
- Disconnect expansion pipe
- Remove expansion vessel securing nut
- Remove vessel
- Check new vessel for correct pressure 1- 1.25 bar
- Refit in reverse order.

6.2 Ignition/Ionisation electrode

- Isolate power supply
- Remove boiler cover
- Remove sealed chamber cover
- Remove PCB cover
- Disconnect ignition lead
- Carefully remove lead through PCB cover and burner compartment
- Remove electrode fixing screw and remove electrode from burner
- Replace in reverse order.

6.3 Main Burner

- Isolate power supply
- Isolate gas supply
- Remove boiler cover
- Remove sealed chamber cover
- Remove burner cover
- Disconnect gas connection to burner
- Remove locknut securing burner assembly
- Remove ignition/ionisation electrode
- Carefully lift out burner assembly
- Refit in reverse order
- Test for gas tightness.

6.4 Fan assembly

- Isolate power supply
- Remove boiler cover
- Remove sealed chamber cover
- Disconnect wiring to fan
- Remove two fan fixing screws
- Carefully pull fan forward and to the right to disconnect fan from post condenser
- Remove air pressure switch sensing tube
- Apply light coating of silicone grease to nozzle of new fan
- Refit in reverse order.

6.5 Main Heat Exchanger

- Isolate power supply
- Isolate gas supply
- Isolate flow and return valves

- Drain boiler using drain vent
- Remove fan assembly as described in 6.4
- Remove 4 screws and remove fan mounting plate
- Disconnect thermistor (SM sensor)
- Disconnect flow and return connections
- Lift out heat exchanger
- Refit in reverse order.

6.6 100°C Limit stat

- Isolate power supply
- Remove boiler cover
- Remove sealed chamber cover
- Remove fan as described in 6.4
- Remove wires from 100°C stat
- Remove stat fixing screws
- Apply heat sink compound to new stat
- Refit in reverse order.

6.7 Air Pressure Switch

- Isolate power supply
- Remove boiler cover
- Remove sealed chamber cover
- Remove screws securing air pressure switch
- Note position of wires before removal
- Note position of sensing tube before removal
- Refit in reverse order.

6.9 Thermistor (SM sensor)

- Isolate power supply
- Remove boiler cover
- Remove sealed chamber cover
- Disconnect thermistor
- Refit in reverse.

6.10 Gas Valve

- Isolate power supply
- Isolate gas supply
- Remove boiler cover
- Disconnect wiring from gas valve
- Disconnect sensing tube
- Remove gas valve
- Refit in reverse order ensuring seals are replaced as required
- Recommission boiler and adjust gas pressures as described in section 4.2.2
- Check for gas tightness

6.11 PUMP HEAD

- Isolate boiler
- Remove cover
- Isolate flow and return valves
- Drain boiler using drain vent
- Remove electrical lead from pump
- Remove 4 x fixing screws from pump housing catching any excess water
- Pull pump forward
- Refit in reverse order

6.12 DOMESTIC HEAT EXCHANGER

- Isolate boiler
- Remove cover
- Isolate flow and return
- Turn on D.H.W tap
- Close cold water supply isolation valve
- Drain boiler using drain vent
- Remove 2 screws securing plate heat exchanger
- Remove plate heat exchanger catching any excess water
- Ensure that the four O rings are removed from the technical assembly
- Fit new O rings supplied with new heat exchanger to the heat exchanger
- Refit in reverse order

6.13 SAFETY VALVE

- Isolate from mains
- Remove cover
- Isolate flow and return valves
- Drain boiler using drain vent
- Disconnect pipe from safety valve
- Remove safety valve securing clip
- Remove safety valve
- Refit in reverse order

6.14 DIVERTER VALVE MOTOR HEAD

- Isolate mains
- Remove cover
- Remove pin from valve head body
- Disconnect lead
- Lift motor upwards
- Refit in reverse order

6.16 AUTO AIR VENT

- Isolate boiler
- Remove cover
- Isolate flow and return valves
- Drain boiler using drain vents
- Pull clip forwards and lift auto air vent upwards
- Refit in reverse order

6.17 DIVERTER CARTRIDGE

- Isolate boiler
- Remove cover
- Isolate flow and return valves
- Drain boiler using drain vent
- Remove air inlet duct
- Disconnect return pipe from pump housing
- Disconnect water gauge pipe from pump housing
- Unplug pump removing top cover
- Remove 2 x screws holding pump and pull forwards catching any excess water
- Remove motor head as 6.14
- Remove pin lift cartridge housing upwards catching any excess water

-
- Refit in reverse order ensure cartridge is locked in position

6.18 WATER PRESSURE SWITCH

- Isolate boiler
- Remove cover
- Isolate flow and return valves
- Drain boiler using drain vent
- Remove clip below flow switch
- Disconnect lead from sensor
- Lift switch upwards
- Refit in reverse order

- Isolate flow and return valves
- Drain boiler using drain vent
- Remove clip
- Pull bypass valve forward
- Refit in reverse order
- Checking seals

6.19 DHW FLOW SENSOR

- Isolate boiler
- Remove cover
- Remove cable from flow sensor and pull forward
- Lift flow sensor blue clip pull forward
- Refit in reverse order

6.20 CONDENSE SENSOR

- Isolate boiler
- Remove cover
- Disconnect the wiring
- Disconnect the sensor
- Refit in reverse order.

6.21 CONDENSE TRAP

- Isolate boiler
- Remove cover
- Remove sensor as described in 6.20
- Remove the screws securing the trap to its mounting bracket.
- Refit in reverse order

6.22 PRINTED CIRCUIT BOARD (PCB)

- Isolate boiler
- Remove cover
- Remove the control panel fixing screws
- Lower the panel to the horizontal position
- Remove the PCB cover
- Disconnect the wiring from the PCB
- Release the plastic "latches" securing the PCB
- Lift out the PCB
- Refit in reverse order
- PAR 1 and PAR2 will need to be set (as shown in section 4.2.1)

6.23 MANUAL BY-PASS

- Isolate boiler
- Remove cover

7 EXPLODED VIEWS

8104022 / 8104026 ECOMFORT PLUS 25 HE -EV

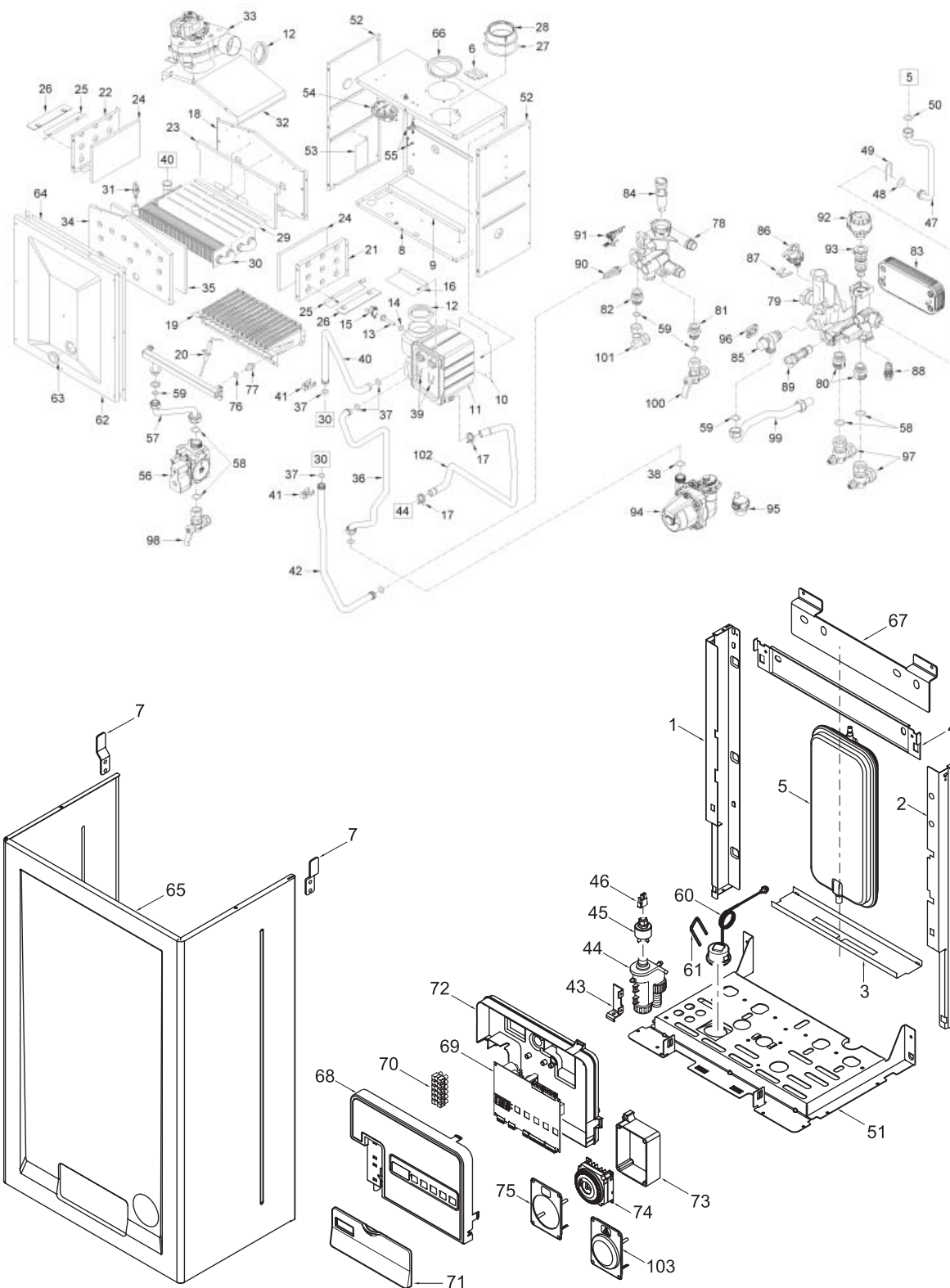

Posiz.	Codice	Descrizione
001	6292541	Left rear frame part
002	6292551	Right rear frame part
003	6255461	Expansion vessel lower support
004	6138771	Frame assembly upper support
005	5183726	Rectang. expansion vessel 8 l.

006	6140012	Expansion vessel support	
007	6140015	Casing fixing bracket	
008	6288120	Sealed chamber rear panel	
009	6257521	Combustion chamber lower air de	
010	6010827	Post-condenser fixing bracket	
011	6300803	Post-condenser	
012	6248855	P.C. inlet/outlet smokes gasket	
013	6112320	P.C. smokes stat extension	
014	6226443	O-Ring Ø 11,5 x 1,5	
015	6146701	100°C safety stat	
016	6257522	Air deflector	
017	2051122	Clamp diam. 22,1	
018	6288432	Combustion chamber rear panel	
019	5190700	Main burner assembly	
020	6235932	Ignition-ionisation electrode	
021	6288510	Combust. chamber right hand sid	
022	6288610	Combust. chamber left hand side	
023	6139773	Combustion chamber rear insulat	
024	6139792	Combustion chamber side insulat	
025	6257519	Comb. chamber right/left air de	
026	6257530	Air deflector	
027	6028707	Air intake gasket	
028	6288000	Air intake	
029	6058811	Smoke deflector	
030	6174257	Heat exchanger	
031	6231369	Plunged sensor	
032	6260616	Smoke chamber upper panel	
033	6225630	Fan	
034	6288720	Combustion chamber front panel	
035	6139786	Combustion chamber front insula	
036	6264856	C.H. return pipe	
037	6226412	O-ring 3068	
038	6226457	O-ring 12bis diam. 16x1,90	
039	6226616	Pipe fixing spring	
040	6227211	Exchanger-post condenser inlet	
041	6226601	Spring for heat exchanger conne	
042	6265130	Heat exchanger outlet pipe	
043	6267130	Water trap support	
044	6277209	Water trap	
045	6319500	Magnetic sensor	
046	6293560	2 pole cable connector	
047	6017310	Flexible pipe	
048	6226464	O-ring 115 diam. 11,91x2,62	
049	6226627	Expansion vassel fixing spring	
050	2030226	Gasket Ø 10,2x14,8x2	
051	6318060	Frame assembly lower side	
052	6288200	Sealed chamber side panel	
053	6215220	Cables protection bracket	
054	6225707	Air pressure switch	
055	6280590	Three way fitting + cap kit	
056	6243820	Gas valve SIT 845 SIGMA	
057	6226893	Gas inlet pipe	
058	2030228	Gasket Ø 17x24x2	
059	2030255	Gasket Ø 12,5x18,5x3	
060	6146111	Hydrometer	
061	6226628	Hydrometer Fixing spring	
062	6288310	Sealed chamber front panel	
063	6001210	Peephole	
064	5192200	Gasket for sealed chamber	
065	6317852	Casing	
066	6028624	Air diaphragm Ø 87.5	
067	6142206	hanging bracket FORMAR.ZIP	
068	6304762	Control panel	
069	6301440	Main PCB	
070	2211010	Terminal strip	
071	6304851	Grey cover	
072	6305050	Control panel cover	
073	6155420	Time programmer box	
074	6197718	Mechanical time programmer	
075	6155421	Time programmer cover	
076	6022004	Copper washer Ø 6	
077	6154402	Main burner nozzle NP 130 natur	MET
077A	6154410	Main burner nozzle NP 77 GLP	LPG
078	6319682	D.H.W. Technyl manifold group	
079	6319681	C.H. Technyl manifold group	
080	6120533	C.H Nipple	
081	6120532	D.H.W. Nipple	

082	6120534	D.H.W. Nipple exit
083	6319690	Kit 14 plate heat exchanger + o
084	6319630	Flowmeter
085	6040211	Pressure relief valve 3 bar
086	6037504	Water pressure switch
087	6226635	Water press.switch fix. spring
088	6319603	Discharger cock
089	6319641	By-pass 2 (new)
090	6319618	Primary filter component
091	6319601	Sensor hall complete
092	6319620	Divertor valve motor
093	6319625	Diverting valve body
094	6272315	Circulating pump
095	6013182	Automatic air vent
097	6177505	Ball cock 3/4" x 22
098	6177530	Gas cock 3/4" F x 15
099	6157648	Pressure relief valve drain pip
100	6177506	Ball cock 1/2" x 15
101	6142330	Quarter bend 1/2" x 15
102	6034163	Condensate drainage pipe
103	6155422	Time programmer cover
701	6319150	6 pole cable connector
702	6316253	9 pole Stocko connector
703	6319152	14 pole cable connector
704	6127214	Main cable L=1500
705	6319151	5 pole cable connector
706	6126040	Two-wire cable L=550
707	5198696	Technyl hydraulic group
708	6319699	Split pin kit for hydraulic gro
709	6319698	O-ring kit for hydraulic group
710	6211793	Hydr.group Bitron caps kit exp
711	6281534	Gaskets kit
712	6319695	O-ring kit
715	5184817	Fitting cocks kit
717	5199540	Complete control panel
719	5144712	Conversion kit to LPG

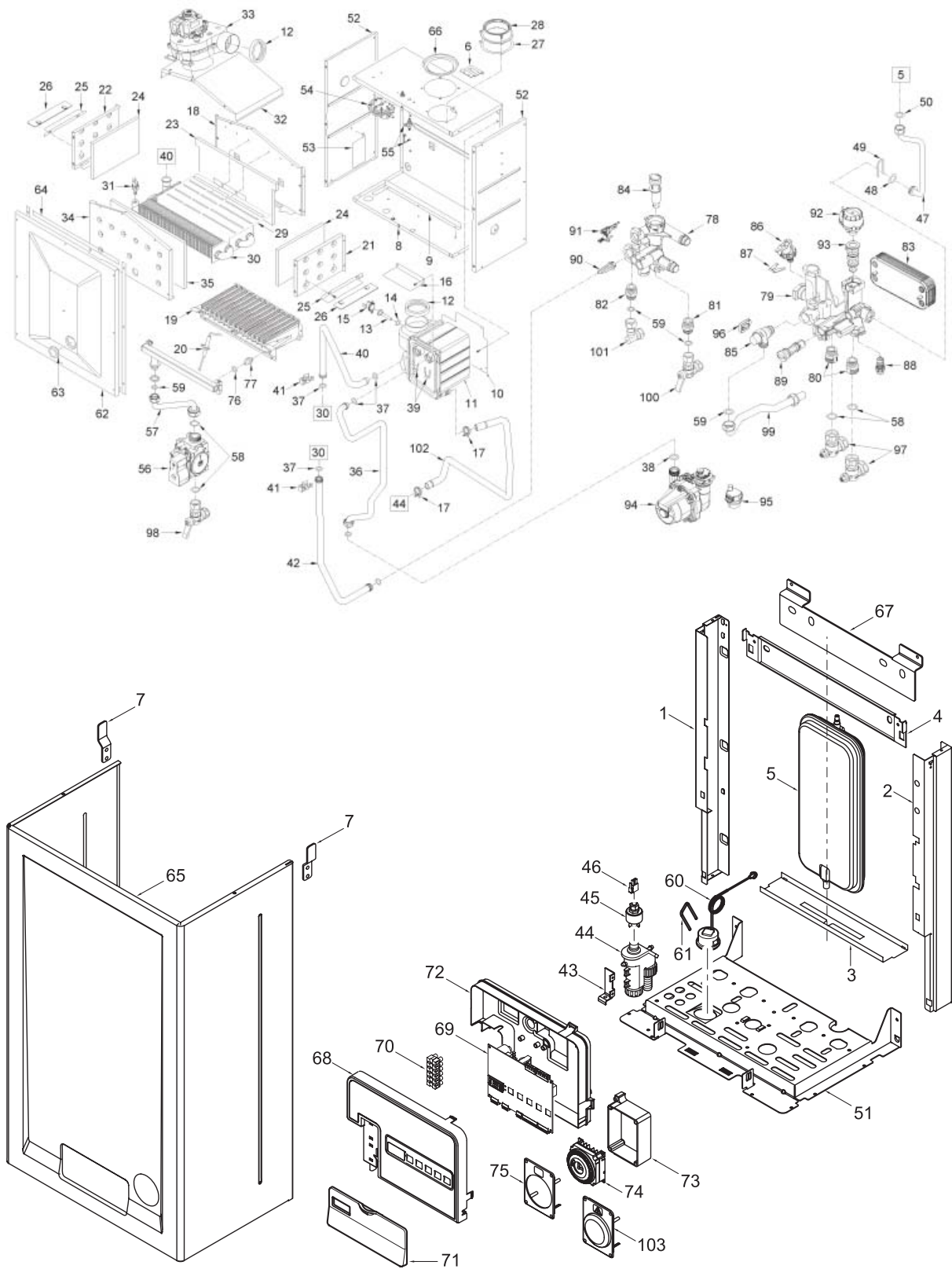

Posiz.	Codice	Descrizione
001	6292541	Left rear frame part
002	6292551	Right rear frame part
003	6255461	Expansion vessel lower support
004	6138771	Frame assembly upper support
005	5183726	Rectang. expansion vessel 8 l.

006	6140012	Expansion vessel support	
007	6140015	Casing fixing bracket	
008	6288120	Sealed chamber rear panel	
009	6257521	Combustion chamber lower air de	
010	6010827	Post-condenser fixing bracket	
011	6300803	Post-condenser	
012	6248855	P.C. inlet/outlet smokes gasket	
013	6112320	P.C. smokes stat extension	
014	6226443	O-Ring Ø 11,5 x 1,5	
015	6146701	100°C safety stat	
016	6257522	Air deflector	
017	2051122	Clamp diam. 22,1	
018	6288432	Combustion chamber rear panel	
019A	5190752	Main burner assembly	
020	6235932	Ignition-ionisation electrode	
021	6288510	Combust. chamber right hand sid	
022	6288610	Combust. chamber left hand side	
023	6139773	Combustion chamber rear insulat	
024	6139792	Combustion chamber side insulat	
025	6257519	Comb. chamber right/left air de	
027	6028707	Air intake gasket	
028	6288000	Air intake	
029	6058811	Smoke deflector	
030	6174257	Heat exchanger	
031	6231369	Plunged sensor	
032	6260616	Smoke chamber upper panel	
033	6225630	Fan	
034	6288720	Combustion chamber front panel	
035	6139786	Combustion chamber front insula	
036	6264856	C.H. return pipe	
037	6226412	O-ring 3068	
038	6226457	O-ring 12bis diam. 16x1,90	
039	6226616	Pipe fixing spring	
040	6227211	Exchanger-post condenser inlet	
041	6226601	Spring for heat exchanger conne	
042	6265130	Heat exchanger outlet pipe	
043	6267130	Water trap support	
044	6277209	Water trap	
045	6319500	Magnetic sensor	
046	6293560	2 pole cable connector	
047	6017310	Flexible pipe	
048	6226464	O-ring 115 diam. 11,91x2,62	
049	6226627	Expansion vassel fixing spring	
050	2030226	Gasket Ø 10,2x14,8x2	
051	6318060	Frame assembly lower side	
052	6288200	Sealed chamber side panel	
053	6215220	Cables protection bracket	
054A	6225715	Air pressure switch	
055	6280590	Three way fitting + cap kit	
056	6243820	Gas valve SIT 845 SIGMA	
057	6226893	Gas inlet pipe	
058	2030228	Gasket Ø 17x24x2	
059	2030255	Gasket Ø 12,5x18,5x3	
060	6146111	Hydrometer	
061	6226628	Hydrometer Fixing spring	
062	6288310	Sealed chamber front panel	
063	6001210	Peephole	
064	5192200	Gasket for sealed chamber	
065	6317852	Casing	
067	6142206	Hanging bracket	
068	6304762	Control panel	
069	6301440	Main PCB	
070	2211010	Terminal strip	
071	6304851	Grey cover	
072	6305050	Control panel cover	
073	6155420	Time programmer box	
074	6197718	Mechanical time programmer	
075	6155421	Time programmer cover	
076	6022004	Copper washer Ø 6	
077	6154402	Main burner nozzle NP 130 natur	MET
077A	6154410	Main burner nozzle NP 77 GLP	LPG
078	6319682	D.H.W. Technyl manifold group	
079	6319681	C.H. Technyl manifold group	
080	6120533	C.H Nipple	
081	6120532	D.H.W. Nipple	
082	6120534	D.H.W. Nipple exit	
083	6319690	Kit 14 plate heat exchanger + o	

084	6319631	Flowmeter
085	6040211	Pressure relief valve 3 bar
086	6037504	Water pressure switch
087	6226635	Water press.switch fix. spring
088	6319603	Discharger cock
089	6319641	By-pass 2 (new)
090	6319618	Primary filter component
091	6319601	Sensor hall complete
092	6319620	Divertor valve motor
093	6319625	Diverting valve body
094	6272315	Circulating pump
095	6013182	Automatic air vent
097	6177505	Ball cock 3/4" x 22
098	6177530	Gas cock 3/4" F x 15
099	6157648	Pressure relief valve drain pip
100	6177506	Ball cock 1/2" x 15
101	6142330	Quarter bend 1/2" x 15
102	6034163	Condensate drainage pipe
103	6155422	Time programmer cover
701	6319150	6 pole cable connector
702	6316253	9 pole Stocko connector
703	6319152	14 pole cable connector
704	6127214	Main cable L=1500
705	6319151	5 pole cable connector
706	6126040	Two-wire cable L=550
707	5198696	Technyl hydraulic group
708	6319699	Split pin kit for hydraulic gro
709	6319698	O-ring kit for hydraulic group
710	6211793	Hydr.group Bitron caps kit exp
711	6281534	Gaskets kit
712	6319695	O-ring kit
715	5184817	Fitting cocks kit
718	5199541	Complete control panel
720	5144719	Conversion kit to LPG

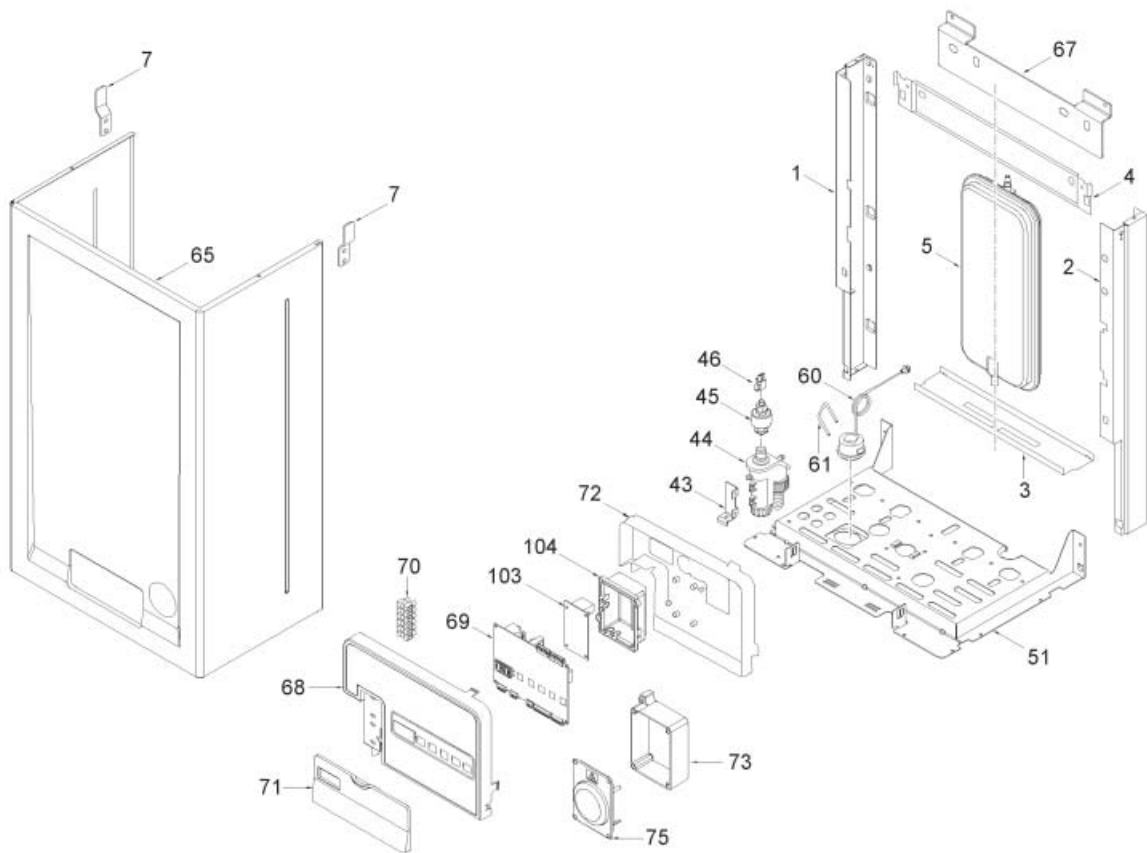
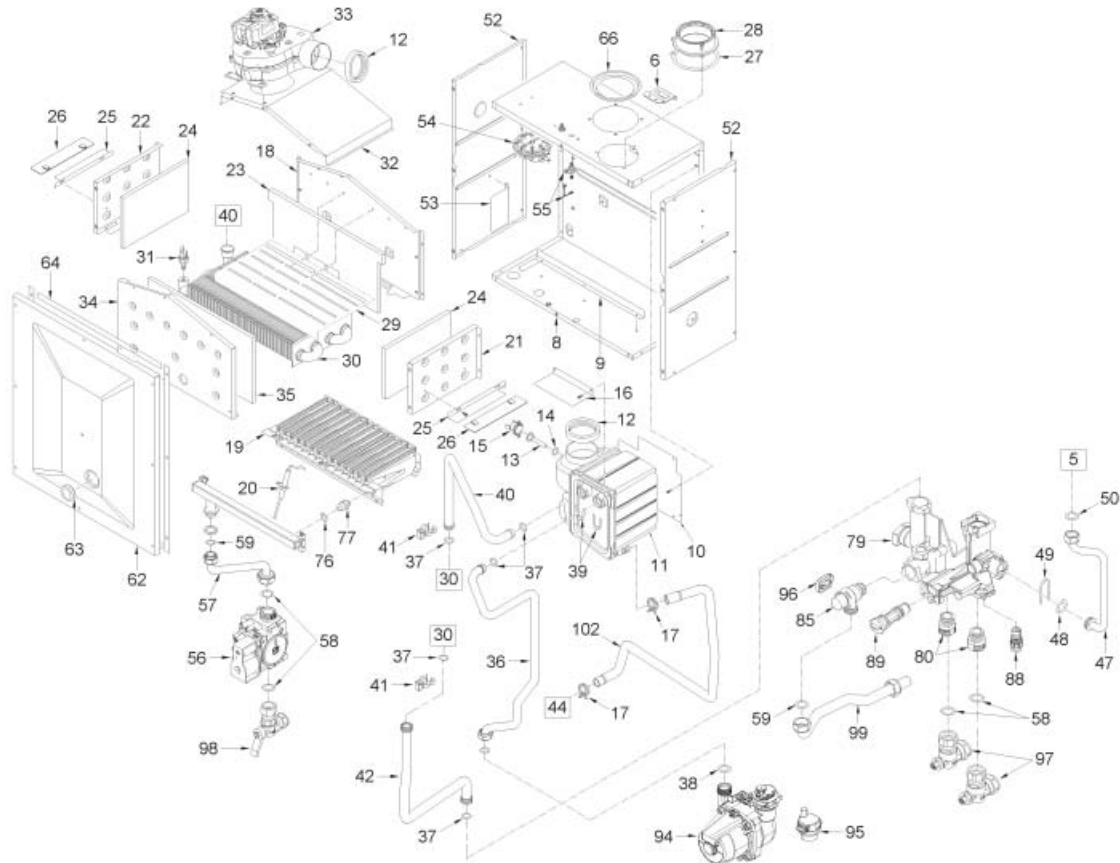

Posiz.	Codice	Descrizione
001	6292541	Left rear frame part
002	6292551	Right rear frame part
003	6255461	Expansion vessel lower support
004	6138771	Frame assembly upper support
005	5183726	Rectang. expansion vessel 8 l.

006	6140012	Expansion vessel support	
007	6140015	Casing fixing bracket	
008	6288120	Sealed chamber rear panel	
009	6257521	Combustion chamber lower air de	
010	6010827	Post-condenser fixing bracket	
011	6300803	Post-condenser	
012	6248855	P.C. inlet/outlet smokes gasket	
013	6112320	P.C. smokes stat extension	
014	6226443	O-Ring Ø 11,5 x 1,5	
015	6146701	100°C safety stat	
016	6257522	Air deflector	
017	2051122	Clamp diam. 22,1	
018	6288432	Combustion chamber rear panel	
019	5190700	Main burner assembly	
020	6235932	Ignition-ionisation electrode	
021	6288510	Combust. chamber right hand sid	
022	6288610	Combust. chamber left hand side	
023	6139773	Combustion chamber rear insulat	
024	6139792	Combustion chamber side insulat	
025	6257519	Comb. chamber right/left air de	
026	6257530	Air deflector	
027	6028707	Air intake gasket	
028	6288000	Air intake	
029	6058811	Smoke deflector	
030	6174257	Heat exchanger	
031	6231369	Plunged sensor	
032	6260616	Smoke chamber upper panel	
033	6225630	Fan	
034	6288720	Combustion chamber front panel	
035	6139786	Combustion chamber front insula	
036	6264856	C.H. return pipe	
037	6226412	O-ring 3068	
038	6226457	O-ring 12bis diam. 16x1,90	
039	6226616	Pipe fixing spring	
040	6227211	Exchanger-post condenser inlet	
041	6226601	Spring for heat exchanger conne	
042	6265131	Heat exchanger outlet pipe	
043	6267130	Water trap support	
044	6277209	Water trap	
045	6319500	Magnetic sensor	
046	6293560	2 pole cable connector	
047	6017310	Flexible pipe	
048	6226464	O-ring 115 diam. 11,91x2,62	
049	6226627	Expansion vassel fixing spring	
050	2030226	Gasket Ø 10,2x14,8x2	
051	6318060	Frame assembly lower side	
052	6288200	Sealed chamber side panel	
053	6215220	Cables protection bracket	
054	6225707	Air pressure switch	
055	6280590	Three way fitting + cap kit	
056	6243820	Gas valve SIT 845 SIGMA	
057	6226893	Gas inlet pipe	
058	2030228	Gasket Ø 17x24x2	
059	2030255	Gasket Ø 12,5x18,5x3	
060	6146111	Hydrometer	
061	6226628	Hydrometer Fixing spring	
062	6288310	Sealed chamber front panel	
063	6001210	Peephole	
064	5192200	Gasket for sealed chamber	
065	6317852	Casing	
066	6028624	Air diaphragm Ø 87.5	
067	6142206	Hanging bracket	
068	6304762	Control panel	
069	6301440	Main PCB	
070	2211010	Terminal strip	
071	6304851	Grey cover	
072	6305050	Control panel cover	
073	6155420	Time programmer box	
075	6155422	Time programmer cover	
076	6022004	Copper washer Ø 6	
077	6154402	Main burner nozzle NP 130 natural gas	MET
077A	6154410	Main burner nozzle NP 77 GLP	LPG
079	6319696	C.H. Technyl manifold group	
080	6120533	C.H Nipple	
085	6040211	Pressure relief valve 3 bar	
088	6319603	Discharger cock	
089	6319641	By-pass	

094	6272315	Circulating pump
095	6013182	Automatic air vent
097	6177505	Ball cock 3/4" x 22
098	6177530	Gas cock 3/4" x 15
099	6157648	Pressure relief valve drain pip
102	6034163	Condensate drainage pipe
103	6301460	Programmer clock expansion boar
104	6305060	Expansion board cover
700	5199542	Complete control panel
702	5144712	Conversion kit to LPG
704	6319150	6 pole cable connector
705	6316253	9 pole Stocko connector
706	6319154	14 pole cable connector
707	6127214	Main cable L=1500
708	6319153	5 pole cable connector
709	6126040	Two-wire cable L=550
710	5184817	Fitting cocks kit
711	5198890	Technyl hydraulic group
712	6211793	Hydraulic group kit
713	6319699	Split pin kit for hydraulic gro
714	6319698	O-ring kit for hydraulic group
715	6281534	Gaskets kit
716	6319695	O-ring kit

Dealing with Condensate

Five suitable drainage points

1. Internal drain stack pipe
2. Waste water pipe *
3. External drain or gully *
4. Rainwater hoppers that carry both rain water and foul water *
5. Purpose-made soakaways

* Care should be taken not to contaminate any "Grey Water Systems"

Pipework

Condensate pipework should be plastic, same as used for standard wastewater plumbing.

Similarly the drainage system where the condensate discharges to should also be resistant to the acidic condensate.

Connection to the internal trap in the boiler can be achieved by using a 20mm solvent weld socket.

Pipework should be kept as short as possible.

External runs should be avoided, but when necessary be a minimum of 3 meters in 32mm diameter pipework and lagged to avoid freezing, this also applies to pipe runs in unheated areas such as garages.

To reduce the possibility of condensate being trapped in the pipe, the number of bends should be kept to a minimum.

Pipework must be angled down from the boiler with a fall of at least 2.5.

The pipework must be supported at a distance of 0.5m for inclined runs and 1.0m for vertical runs.

Condensate traps

Where the condensate drain is not sealed to the discharge connection a trap will be required. The water seal should be 38mm or more for external discharge and 75mm or more for internal discharge. When connecting to an external stack the trap should be located within the building.

Stack Pipes

Condensate connections should be at least 450mm above any bend at the bottom of a stack pipe in a single or multi-story dwelling up to 3 storeys.

There are specific requirements when connecting to a stack pipe serving multi-storey buildings greater than 3 storeys.

All connections to stack pipes should avoid across flow between other Branch pipes.

Soakaways

Any soakaways have to be purpose-made and located as close to the boiler as possible, but clear of the buildings foundations and any buried services. The best option is to purchase a soakaway from a drainage manufacturer and install it to the manufacturer's recommendation.



Sime Ltd

1a Blue Ridge Park
Thunderhead Ridge
Glasshoughton, Castleford, WF10 4UA

Phone: 0845 9011114

Fax: 0845 9011115

www.sime.co.uk

Email: enquiries@sime.co.uk