

Installation and service instructions

for contractors

VIESSMANN

Vitodens 050-W

Type BPJD, 6.5 to 35.0 kW

Wall mounted gas condensing boiler

For natural gas and LPG

Gas Council Number: 47 819 31, 47 819 32



VITODENS 050-W



Safety instructions



Please follow these safety instructions closely to prevent accidents and material losses.

Safety instructions explained



Danger

This symbol warns against the risk of injury.

Note

Details identified by the word "Note" contain additional information.



Please note

This symbol warns against the risk of material losses and environmental pollution.

Target group

These instructions are exclusively intended for qualified contractors.

- Work on gas installations may only be carried out by a registered gas fitter.
- Work on electrical equipment may only be carried out by a qualified electrician.
- The system must be commissioned by the system installer or a qualified person authorised by the installer.

Regulations to be observed

- National installation regulations
- Statutory regulations for the prevention of accidents
- Statutory regulations for environmental protection
- Codes of practice of the relevant trade associations
- All current safety regulations as defined by DIN, EN, DVGW, TRGI, TRF, VDE and all locally applicable standards
 - Ⓐ ÖNORM, EN, ÖVGW G K directives, ÖVGW-TRF and ÖVE
 - Ⓒ SEV, SUVA, SVGW, SVTI, SWKI, VKF and EKAS guideline 1942: LPG, part 2

Safety instructions (cont.)

Safety instructions for working on the system

Working on the system

- Where gas is used as the fuel, close the main gas shut-off valve and safeguard it against unintentional reopening.
- Isolate the system from the power supply, e.g. by removing the separate fuse or by means of a mains isolator, and check that it is no longer live.
- Safeguard the system against reconnection.
- Wear suitable personal protective equipment when carrying out any work.



Danger

Hot surfaces can cause burns.

- Before maintenance and service work, switch OFF the appliance and let it cool down.
- Never touch hot surfaces on the boiler, burner, flue system or pipework.



Please note

Electronic assemblies can be damaged by electrostatic discharge.

Prior to commencing work, touch earthed objects such as heating or water pipes to discharge static loads.

Repair work



Please note

Repairing components that fulfil a safety function can compromise the safe operation of the system.

Replace faulty components only with genuine Viessmann spare parts.

Auxiliary components, spare and wearing parts



Please note

Spare and wearing parts that have not been tested together with the system can compromise its function. Installing non-authorized components and making non-approved modifications or conversions can compromise safety and may invalidate our warranty.

For replacements, use only original spare parts supplied or approved by Viessmann.

Safety instructions (cont.)

Safety instructions for operating the system

If you smell gas



Danger

Escaping gas can lead to explosions which may result in serious injury.

- Do not smoke. Prevent naked flames and sparks. Never switch lights or electrical appliances on or off.
- Close the gas shut-off valve.
- Open windows and doors.
- Evacuate any people from the danger zone.
- Notify your gas or electricity supply utility from outside the building.
- Have the power supply to the building shut off from a safe place (outside the building).

If you smell flue gas



Danger

Flue gas can lead to life threatening poisoning.

- Shut down the heating system.
- Ventilate the installation site.
- Close doors to living spaces to prevent flue gases from spreading.

What to do if water escapes from the appliance



Danger

If water escapes from the appliance there is a risk of electrocution.

Switch OFF the heating system at the external isolator (e.g. fuse box, domestic distribution board).



Danger

If water escapes from the appliance there is a risk of scalding. Never touch hot heating water.

Condensate



Danger

Contact with condensate can be harmful to health. Never let condensate touch your skin or eyes and do not swallow it.

Flue systems and combustion air

Ensure that flue systems are clear and cannot be sealed, for instance due to accumulation of condensate or other external causes.

Avoid continuous condensate disposal with a wind protector.

Ensure an adequate supply of combustion air.

Inform system users that subsequent modifications to the building characteristics are not permissible (e.g. cable/pipework routing, cladding or partitions).

Safety instructions (cont.)**Danger**

Leaking or blocked flue systems, or an inadequate supply of combustion air can cause life threatening poisoning from carbon monoxide in the flue gas. Ensure the flue system is in good working order. Vents for supplying combustion air must be non-sealable.

**Danger**

The simultaneous operation of the boiler and appliances that exhausts air to the outside can result in life threatening poisoning due to a reverse flow of flue gas. Fit an interlock circuit or take suitable steps to ensure an adequate supply of combustion air.

Extractors

Operating appliances that exhaust air to the outside (extractor hoods, extractors, air conditioning units, etc.) can create negative pressure. If the boiler is operated at the same time, this can lead to a reverse flow of flue gas.

Index

Installation instructions

Information

Disposal of packaging.....	8
Symbols.....	9
Intended use.....	10
Product information.....	10

Preparing for installation.....	13
--	-----------

Installation sequence

Mounting the boiler and making connections.....	17
Opening the programming unit.....	22
Electrical connections.....	23

Service instructions

Commissioning, inspection, maintenance

Steps - commissioning, inspection and maintenance.....	26
Further details regarding the individual steps.....	27

Troubleshooting

Function sequence and possible faults.....	50
Fault display.....	51
Repairs.....	56

Changing the gas type

Converting from LPG to natural gas.....	67
---	----

Control unit

Functions and operating conditions in weather-compensated mode.....	69
---	----

Designs

Connection and wiring diagrams.....	71
-------------------------------------	----

Parts lists

Overview of assemblies.....	76
Casing assembly.....	78
Heat cell assembly.....	80
Burner assembly.....	82
Hydraulic assembly.....	84
Grundfos hydraulic assembly.....	86
Control unit assembly.....	88
Miscellaneous assembly.....	90

Index (cont.)









Specification	91
Disposal	
Final decommissioning and disposal.....	92
Certificates	
Declaration of conformity.....	93
Keyword index	95

Disposal of packaging

Please dispose of packaging waste in line with statutory regulations.

- DE:** Use the disposal system organised by Viessmann.
- AT:** Use the ARA statutory disposal system (Altstoff Recycling Austria AG, licence number 5766).
- CH:** Packaging waste is disposed of by the HVAC contractor.

Symbols

Sym- bol	Meaning
	Reference to other document containing further information
	Step in a diagram: The numbers correspond to the order in which the steps are carried out.
	Warning of material losses and environmental pollution
	Live electrical area
	Pay particular attention.
	<ul style="list-style-type: none"> ■ Component must audibly click into place. or ■ Acoustic signal
	<ul style="list-style-type: none"> ■ Fit new component. or ■ In conjunction with a tool: Clean the surface.
	Dispose of component correctly.
	Dispose of component at a suitable collection point. Do not dispose of component in domestic waste.

Intended use

The appliance is intended solely for installation and operation in sealed unvented heating systems that comply with EN 12828, with due attention paid to the associated installation, service and operating instructions. It is only designed for heating up heating water that is of potable water quality.

Intended use presupposes that a fixed installation in conjunction with permissible, system-specific components has been carried out.

Commercial or industrial usage for a purpose other than heating the building or DHW shall be deemed inappropriate.

Any usage beyond this must be approved by the manufacturer in each individual case.

Incorrect usage or operation of the appliance (e.g. the appliance being opened by the system user) is prohibited and will result in an exclusion of liability. Incorrect usage also occurs if the components in the heating system are modified from their intended use (e.g. if the flue gas and ventilation air paths are sealed).

Product information

Vitodens 050-W, type BPJD

Preset for operation with natural gas. Conversion to LPG P requires a gas conversion kit.

Gas Council No.

- 29 kW combi: 47 819 31
- 35 kW combi: 47 819 32

Conversion for other countries

The Vitodens 050-W may generally only be delivered to countries listed on the type plate. For deliveries to other countries, approved contractors must arrange individual approval on their own initiative and in accordance with the law of the country in question.

Product description

The Vitodens 050-W is available as a gas condensing combi boiler with integral plate heat exchanger for DHW heating. For the connection of heating circuits and the DHW line, see page 16 onwards.

The Vitodens 050-W is set up for operation with a constant boiler water temperature.

The appliance is equipped with a sealed unvented hydraulic system with 2 connections for the heating flow and return and 2 connections for DHW heating.

Product information (cont.)

The following components are integrated into the hydraulic system:

- Circulation pump
- 3-way diverter valve
- Safety valve
- Diaphragm expansion vessel
- Plate heat exchanger for DHW heating

Connecting accessories

A time switch (accessories) can be connected to the control unit with a low voltage supply.

Siting

Suitable siting locations include:

- Recreational rooms and other living spaces
- Ancillary rooms without their own ventilation

- Cupboards (open at the top)
- Recesses without compulsory clearance towards combustible materials
- Attic rooms (pitched attics and long panes) where the balanced flue pipe can be routed directly through the roof

Since the flue pipe connection for room sealed operation is surrounded by combustion air (coaxial pipe), no clearances towards combustible materials need be maintained. For further details, see the technical guide on flue systems for the Vitodens.

The installation room must be safe from the risk of frost.

Operation of the Vitodens 050-W in wet rooms

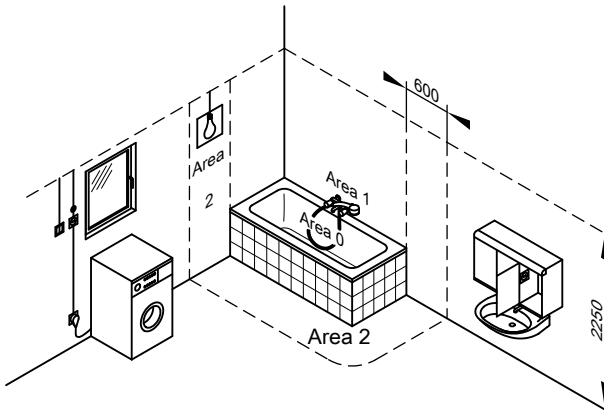

Product information (cont.)

The Vitodens is approved for installation in wet rooms (e.g. bathroom or shower rooms) (protection IP X4 D, splashproof).

When installing the Vitodens in wet rooms, observe the safety zones and minimum wall clearances according to VDE 0100 [or local regulations] (see also "Electrical safety zone"). The Vitodens may be installed **in safety zone 1** if hosed water (e.g. from massage showers) is prevented.

Electrical equipment in rooms containing a bathtub or a shower must be installed in such a way that users cannot be exposed to dangerous body currents.

VDE 0100 specifies that cables supplying permanently installed consumers in zones 1 and 2 should only be run vertically and routed into the equipment from the back.

Preparing for installation (cont.)

Minimum clearances

Maintain a clearance of 700 mm in front of the Vitodens for maintenance purposes. Maintenance clearances to the l.h. or r.h. side of the Vitodens are **not** required.

Preparing for installation (cont.)

Fitting the wall mounting bracket

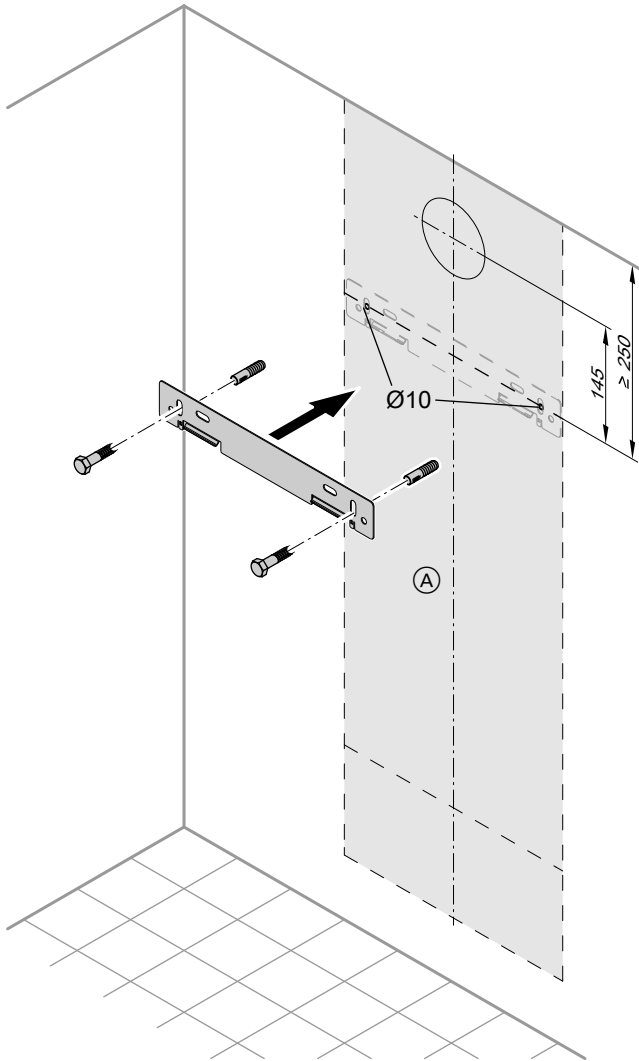

Ⓐ Vitodens installation template

Preparing for installation (cont.)

1. Position the supplied installation template on the wall.
 2. Mark out the rawl plug holes.
 3. Drill \varnothing 10 mm holes and insert the rawl plugs supplied.
 4. Fit the wall mounting bracket with the screws supplied.
1. Prepare the water connections. Flush the heating system.
 2. Prepare the gas connection.
 3. Prepare the electrical connections.
 - Cables for accessories:
Sheathed cable, 2-core. For low voltage, min. 0.5 mm².

Fitting the pre-plumbing jig or mounting frame



Pre-plumbing jig or mounting frame installation instructions

Preparing the connections



Please note

To prevent appliance damage, connect all pipework free of load and torque stress.

Installation in a cupboard

Any cupboard enclosing the appliance must be designed and constructed specifically for this purpose. An existing cupboard or closet may be used, provided it is modified accordingly. BS 7698:2000 gives details of the essential design features for cupboards and closets, including airing cupboards. The Vitodens range does not require the cupboard to be ventilated.

Mounting the boiler and making connections

Removing the front panel and mounting the boiler

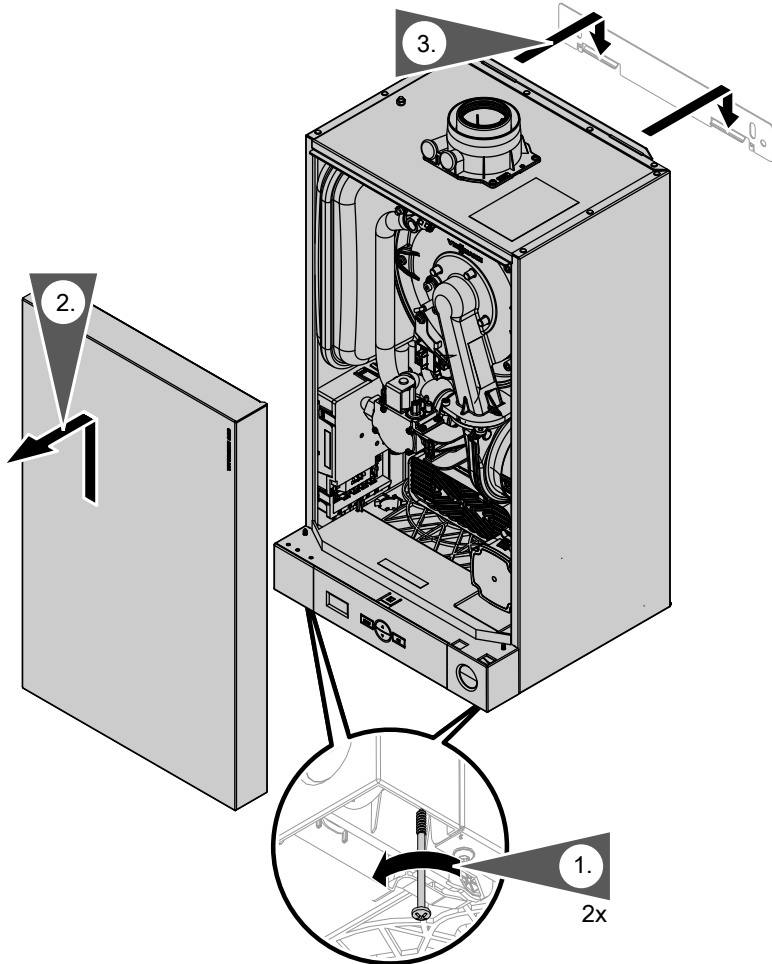

1. Undo the screws on the underside of the boiler; do not remove them completely.
2. Remove front panel.
3. Hook the boiler into the wall mounting bracket.

Mounting the boiler and making connections (cont.)

Fitting the connections on the water side



Please note

Protect pressure gauge hoses when welding/soldering copper pipes to the boiler.

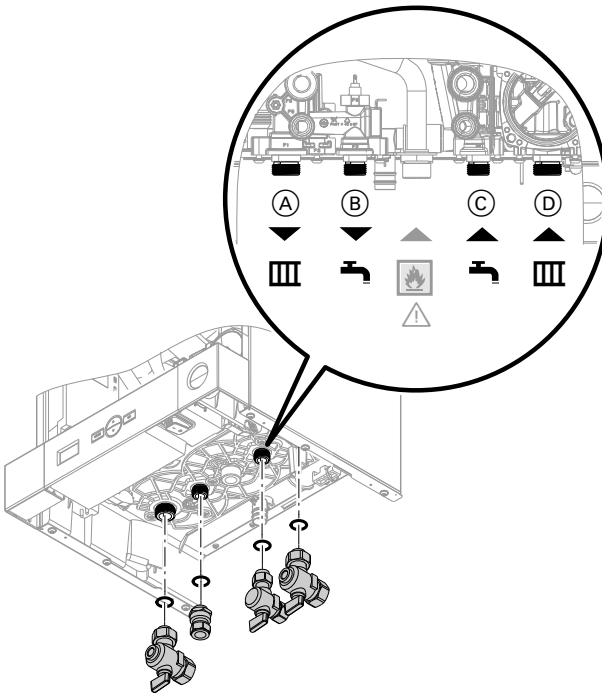

- (A) Heating flow G $\frac{3}{4}$
- (B) DHW G $\frac{1}{2}$
- (C) Cold water G $\frac{1}{2}$

- (D) Heating return G $\frac{3}{4}$

1. Mount the fittings with gaskets.
2. Install the filling equipment on site. The filling equipment must comply with the Fittings Directive G24.2a.

Mounting the boiler and making connections (cont.)

Gas connection

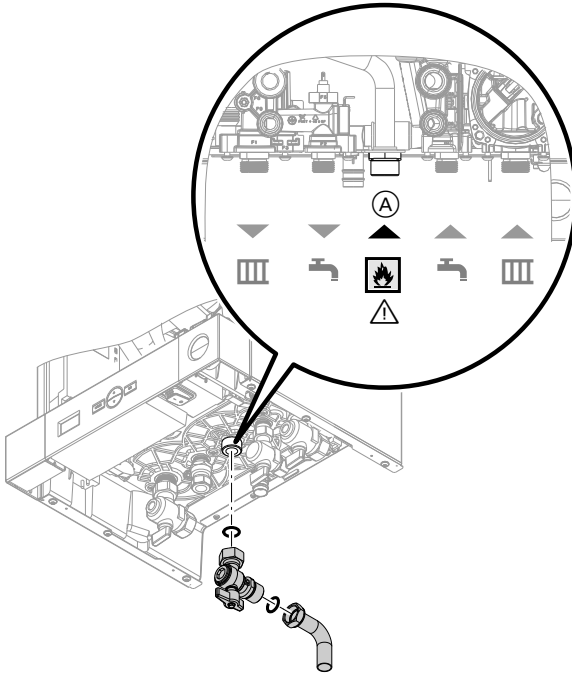

1. Fit the gas shut-off valve with bend to connection (A).
3. Carry out a tightness test.

2. Connect the gas supply to connection (A).

Note

Only use suitable and approved leak detection agents (EN 14291) and devices for the tightness test. Leak detection agents with unsuitable constituents (e.g. nitrides, sulphides) can cause material damage.

Remove residues of the leak detection agent after testing.



Mounting the boiler and making connections (cont.)



Please note

Excessive test pressure will damage the boiler and the gas train.

Max. test pressure 150 mbar (15 kPa). Where higher pressure is required for tightness tests, disconnect the boiler and the gas train from the main supply pipe (undo the fitting).

4. Purge the gas line.

Connecting the safety valve and condensate drain

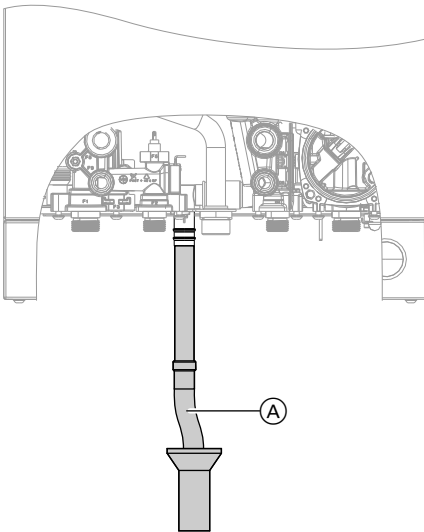

- If the condensate pipe is routed outside the building, use a pipe with min. \varnothing 30 mm and protect the pipe from frost. Avoid long external pipe runs. Install a tundish.



Please note

A frozen condensate pipe can result in faults and damage to the boiler.

Always protect condensate pipes against frost.

- Observe local building regulations. Connect condensate pipe (A) to the public sewage system with a constant fall and a pipe vent. Observe local waste water regulations.

- The condensate pipe is connected to the discharge pipe of the safety valve. The condensate hose supplied meets the temperature requirements that are part of the CE certification.
- We recommend connecting the condensate pipe to the internal domestic waste water system, either directly or via a tundish.

Note

Fill the trap with water before commissioning.

Mounting the boiler and making connections (cont.)

Filling the trap with water

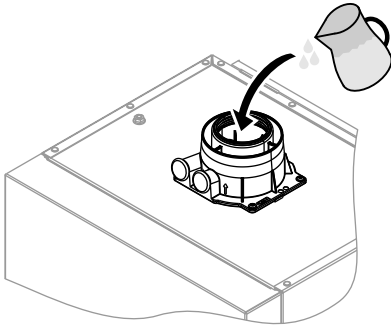

Pour at least 0.3 l of water into the flue gas connection.



Please note

During commissioning, flue gas may escape from the condensate drain.

Always fill the trap with water before commissioning.

Balanced flue connection

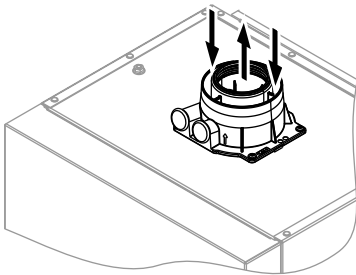

Connect the balanced flue pipe. During installation and positioning of the flue system, observe Part J of the Building Regulations and BS 5440.



Flue system installation instructions

Connecting several Vitodens 050-W to a shared flue system

Adjust the burner settings of each connected boiler to match the flue system. See page 33.

Do not carry out **commissioning** until the following conditions are met:

- Free passage through the flue gas pipes.
- Flue system with positive pressure is gas-tight.
- Inspection port covers checked for secure and tight seating.
- Apertures for ensuring sufficient combustion air supply are open and cannot be closed off.
- Applicable regulations on installing and commissioning flue systems have been followed.

Mounting the boiler and making connections (cont.)



Danger

Leaking or blocked flue systems or an insufficient supply of combustion air cause life threatening poisoning due to carbon monoxide in the flue gas.

Ensure the flue system functions correctly. Apertures for combustion air supply must not be able to be closed off.

Prevent condensate drainage via a wind protector.

Opening the programming unit

Only required if a wireless receiver or time switch (accessories) is to be connected.

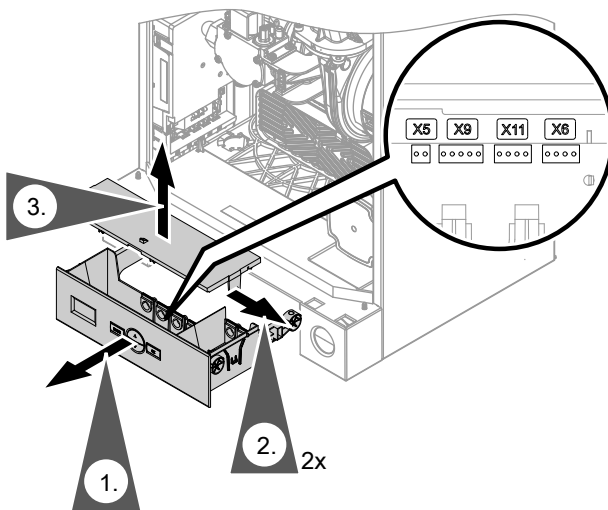

Please note

Electronic assemblies can be damaged by electrostatic discharge.

Prior to commencing any work, touch earthed objects such as heating or water pipes to discharge static loads.

Electrical connections

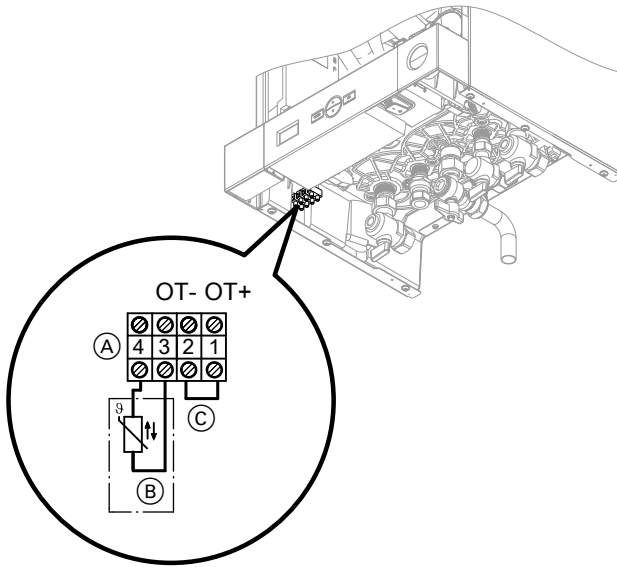

- (A) Terminals on underside of appliance
- (B) Outside temperature sensor
- (C) Vitotrol 100 or on-site room temperature controller with LV switching contact and low transition resistance
Remove jumper when connecting.



Information on connecting accessories

When connecting accessories observe the separate installation instructions provided with them.



Separate installation instructions

Electrical connections (cont.)

Outside temperature sensor (accessories)

1. Fit the outside temperature sensor.

Installation location:
 - North or north-westerly wall, 2 to 2.5 m above ground level; in multi storey buildings, in the upper half of the second floor
 - Not above windows, doors or vents
 - Not immediately below balconies or gutters
 - Never render over.
 - Connection:
2-core lead, length up to 35 m with a cross-section of 1.5 mm²
2. Connect the outside temperature sensor across terminals 3 and 4 (underside of appliance).

Power supply

Connect the power cable to the building mains.

Regulations and directives



Danger

Incorrectly executed electrical installations can result in injuries from electrical current and damage to the appliance.

Connect the power supply and implement all safety measures (e.g. RCD circuit) in accordance with the following regulations:

- IEC 60364-4-41
- VDE regulations
- Connection requirements specified by your local power supply utility

Install an isolator in the power cable to provide omnipolar separation from the mains for all active conductors, corresponding to overvoltage category III (3 mm) for full isolation. The isolator must be fitted in the permanent electrical installation, in line with installation requirements.

Protect the power cable with an external 3 A fuse to BS 1362.



Danger

Incorrect core assignment can result in serious injury and damage to the appliance.

Take care **not** to interchange wires "L1" and "N".

Electrical connections (cont.)

**Danger**

The absence of component earthing can lead to serious injury from electric current if an electrical fault occurs.

The appliance and pipework must be connected to the equipotential bonding of the building.

Routing connecting cables/leads

**Please note**

Connecting cables/leads will be damaged if they touch hot components.

When routing and securing cables/leads on site, ensure that the maximum permissible temperature for these is not exceeded.

Steps - commissioning, inspection and maintenance

For further information regarding the individual steps, see the page indicated

			Commissioning steps	Inspection steps	Maintenance steps	Page
•	•	•	1. Filling the heating system.....			27
•	•	•	2. Converting to operation with LPG.....			29
•	•	•	3. Checking the static pressure and supply pressure....			29
•	•	•	4. Reducing the maximum heating output.....			31
•	•	•	5. Matching the burner output to the flue system.....			32
•	•	•	6. Burner adjustment when connecting multiple flues to a shared flue system.....			33
•	•	•	7. Checking the CO₂ content.....			37
•	•	•	8. Removing the burner			41
•	•	•	9. Checking the burner gasket and burner gauze assembly.....			41
•	•	•	10. Checking and adjusting the electrode.....			43
•	•	•	11. Cleaning the heat exchanger.....			43
•	•	•	12. Checking the condensate drain and cleaning the trap.....			45
•	•	•	13. Installing the burner			46
•	•	•	14. Checking the diaphragm expansion vessel and system pressure.....			47
•	•	•	15. Checking all connections on the heating water and DHW sides for leaks			
•	•	•	16. Checking the firm seating of electrical connections			
•	•	•	17. Checking all gas equipment for tightness at operating pressure			47
•	•	•	18. Fitting the front panel.....			48
•	•	•	19. Instructing the system user.....			49

Further details regarding the individual steps

Filling the heating system



Please note

Unsuitable fill water increases the level of deposits and corrosion and may lead to boiler damage.

- Flush the heating system thoroughly before filling.
- Only fill with water of potable quality.

- Fill water with a hardness above 300 ppm must be softened.
- Special antifreeze suitable for heating systems can be added to the fill water.

1. Close the gas shut-off valve.
2. Switch on the power supply at ON/OFF switch (A).
3. Activate the filling function.
 1. Press MODE and ▲ simultaneously and hold for approx. 3 s. "SERV" is displayed and "1" flashes.
 2. OK to confirm. "0" flashes on the display.
 3. Use ▲/▼ to set "1"
 4. OK to confirm. The filling function is active.

Note

The function is terminated by resetting the value to "0" or by turning off the ON/OFF switch.

The function will terminate automatically after 30 min.



Further details regarding the individual steps (cont.)

4. Open shut-off valves **(B)** and **(C)**.

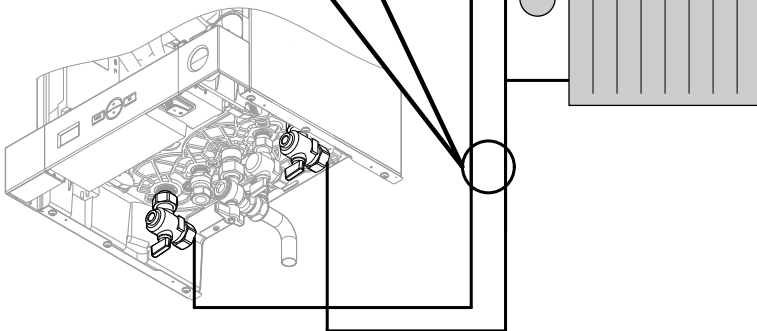
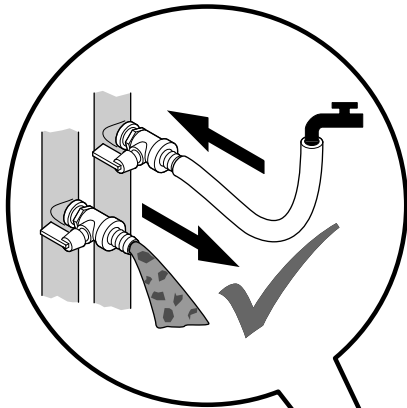
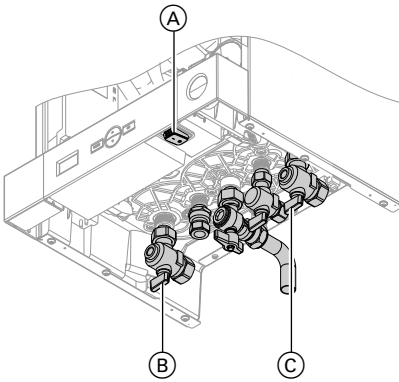

Further details regarding the individual steps (cont.)

5. Fill and vent the heating system using the on-site valve. System pressure 0.8 to 1.2 bar (0.08 to 0.1 MPa).
The system can be filled using a separate filling point fitted at a convenient position in the heating circuit. The connection must be removed when filling is complete. Where local water authority regulations do not allow temporary connections, a sealed system filler pump with break tank must be used. The heating system will not be filled automatically from the domestic hot water side. Alternative methods for filling sealed systems are provided in BS 5449.

Converting to operation with LPG

In the delivered condition, the boiler is set up for operation with natural gas. For operation with LPG, change the gas nozzle and switch to the correct gas type at the control unit.



Separate installation instructions

For conversion from LPG to natural gas, see page 67.

Checking the static pressure and supply pressure



Danger

CO formation as a result of incorrect burner adjustment can have serious health implications. Always carry out a CO test before and after work on gas appliances.

Operation with LPG

Purge the LPG tank twice on commissioning or replacement. Vent the tank and gas connection line thoroughly after purging.

Further details regarding the individual steps (cont.)

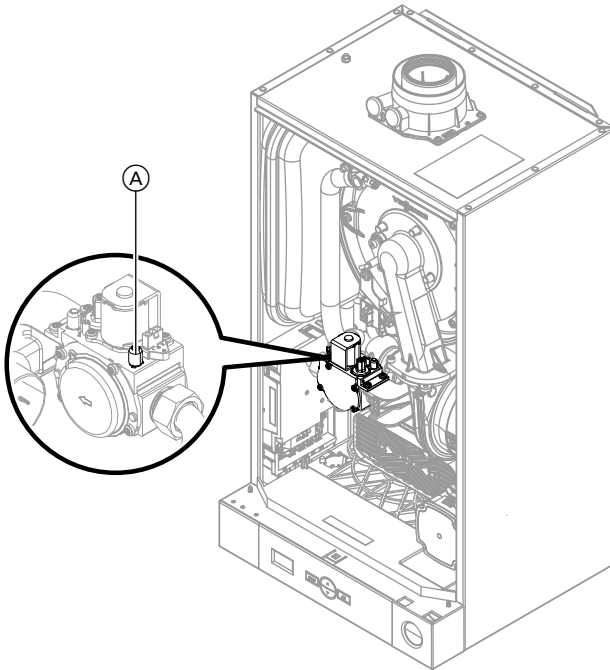

Gas train viewed from behind

1. Close the gas shut-off valve.
2. Undo screw (A) inside test connector "IN" on the gas train, but do not remove it. Connect the pressure gauge.
3. Open the gas shut-off valve.
4. Check the static pressure.
Set value: max. 57.5 mbar
(5.75 kPa)
5. Start the boiler.

Note

*During commissioning, the appliance can enter a fault state because of airlocks in the gas line. After approx. 5 s, press **Reset** to reset the burner (see page 54).*

Further details regarding the individual steps (cont.)

6. Check the supply (flow) pressure.

Set value:

- Natural gas: 20 mbar (2.0 kPa)
- LPG: 37 mbar (3.7 kPa)

Note

Use a suitable measuring device with a resolution of at least 0.1 mbar (0.01 kPa) to check the supply pressure.

7. Implement measures as indicated in the table below.

8. Shut down the boiler, close the gas shut-off valve, remove the pressure gauge and tighten the screw in test connector (A).

9. Open the gas shut-off valve and start the appliance.



Danger

Gas escaping from the test connector leads to a risk of explosion.
Check gas tightness at test connector (A).

Supply pressure (flow pressure)		Steps
For natural gas	For LPG	
Below 17.4 mbar (1.74 kPa)	Below 25 mbar (2.5 kPa)	Do not commission the boiler. Notify the gas supply utility or LPG supplier.
17.4 to 25 mbar (1.74 to 2.5 kPa)	25 to 47 mbar (2.5 to 4.7 kPa)	Start the boiler.
Above 25 mbar (2.5 kPa)	Above 47 mbar (4.7 kPa)	Install a separate gas pressure governor upstream of the system and set the flow pressure to 20 mbar (2.0 kPa) for natural gas or 37 mbar (3.7 kPa) for LPG. Notify the gas supply utility or LPG supplier.

Reducing the maximum heating output

The maximum heating output can be reduced in 25 % increments according to system requirements.

1. Press MODE and ▲ simultaneously and hold for 3 s. "SERV" appears on the display and "I" flashes.

2. Use ▲/▼ to select "2" and confirm with OK. "00" flashes on the display (corresponds to 100 % burner output).
3. Use ▲/▼ to select the required burner output and confirm with OK.

Further details regarding the individual steps (cont.)

4. Press MODE and ▲ simultaneously and hold for 3 s.
Service mode is terminated. Service mode also terminates automatically after 30 min.
5. Start the boiler.
6. Check the selected burner output by measuring the gas throughput at the upper heating output.

Matching the burner output to the flue system

To match the burner output to the system flue pipe length, a correction factor can be set.

Note

Observe max. flue pipe lengths in the pricelist. If the max. flue pipe lengths in the pricelist are exceeded, a calculated performance verification is required.

1. Press MODE and ▲ simultaneously and hold for 3 s.
"SERV" appears on the display and "I" flashes.
2. Use ▲/▼ to select "3" and confirm with OK.
"0" flashes on the display.
3. Look up the required correction factor relevant to the length of the flue in the tables below.
4. Use ▲/▼ to set the required correction factor and confirm with OK.
5. Press MODE and ▲ simultaneously and hold for 3 s.
Service mode is terminated. Service mode also terminates automatically after 30 min.

Open flue operation Ø 60 mm

Correction factor	0	1	2	3	4	5	6
Rated heating output (kW)	Flue pipe length (m)						
24	≤ 8	> 8 ≤ 15	Do not adjust				
33	≤ 8	> 8 ≤ 14	> 14 ≤ 19	> 19 ≤ 25	Do not adjust		

Further details regarding the individual steps (cont.)

Room sealed operation \varnothing 60 mm coaxial

Correction factor	0	1	2	3	4	5	6
Rated heating output (kW)	Flue pipe length (m)						
24	≤ 4	$> 4 \leq 8$	$> 8 \leq 12$	$> 12 \leq 15$	Do not adjust		
33	≤ 4	$> 4 \leq 7$	$> 7 \leq 11$	$> 11 \leq 20$	Do not adjust		

Burner adjustment when connecting multiple flues to a shared flue system

When connecting several Vitodens 050-W to a shared flue system: Adjust the burner settings of each connected boiler by a correction factor to match them to the flue system.

System conditions:

- Shared flue in shaft \varnothing 100 mm
- Balanced flue connection pipe from boiler to shaft, \varnothing 80/125 mm
- Minimum shaft cross-section
 - Square: 175 x 175 mm
 - Round: \varnothing 195 mm
- Height between floors min. 2.5 m
- Max. 4 boilers with the same rated heating output connected to the flue system

1. Press MODE and \blacktriangle simultaneously and hold for 3 s.
"SERV" appears on the display and "I" flashes.

2. Use $\blacktriangle/\blacktriangledown$ to select "4" and confirm with OK.
"0" flashes on the display.
3. Refer to the following tables for the correction factor required for the flue system.
4. Use $\blacktriangle/\blacktriangledown$ to set the required correction factor and confirm with OK.
5. Press MODE and \blacktriangle simultaneously and hold for 3 s.
Service mode is terminated. Service mode also terminates automatically after 30 min.

Further details regarding the individual steps (cont.)

One boiler per floor

Rated heating output 24 kW

Number of boilers	2	3	4
Correction factor (adjustable value)	Flue length a (m)		
0			
1	≤ 21		
2	> 21 ≤ 25	≤ 19	≤ 13
3	–	> 19 ≤ 25	> 13 ≤ 17
4	–	–	> 17 ≤ 21
5	–	–	–
6	–	–	–

Rated heating output 33 kW

Number of boilers	2	3	4
Correction factor (adjustable value)	Flue length a (m)		
0			
1	≤ 12		
2	> 12 ≤ 25	≤ 17	
3	–	≤ 16	
4	–	> 16 ≤ 20	≤ 14
5	–	> 20 ≤ 25	> 14 ≤ 16
6	–	–	> 16 ≤ 18

Note

The correction factor changes the boiler modulation range.

Further details regarding the individual steps (cont.)

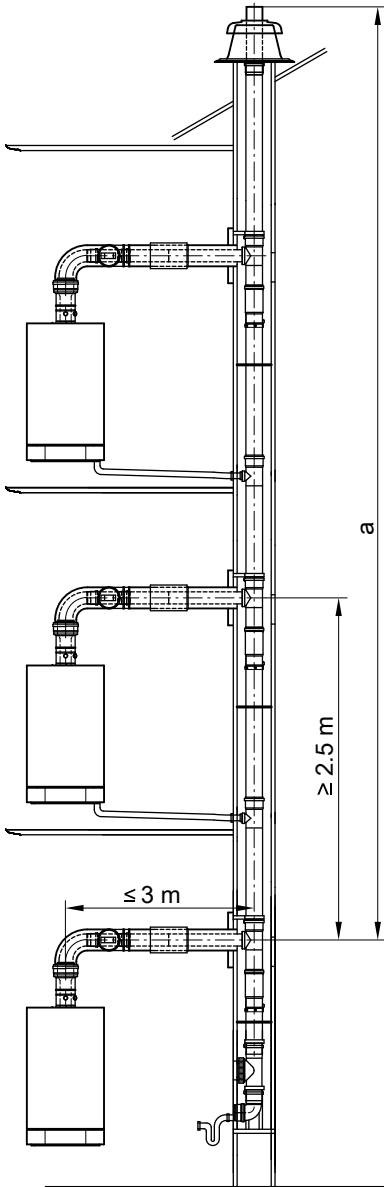

Further details regarding the individual steps (cont.)

Two boilers per floor

Rated heating output 24 kW

Number of boilers	2	4
Correction factor (adjustable value)	Flue length a (m)	
0		
1	≤15	≤5
2	–	> 5 ≤ 9
3	–	> 9 ≤ 14
4	–	> 14 ≤ 15
5	–	–
6	–	–

Rated heating output 33 kW

Number of boilers	2	4
Correction factor (adjustable value)	Flue length a (m)	
0		
1	≤ 9	
2	> 9 ≤ 15	≤ 6
3	–	> 6 ≤ 8
4	–	> 8 ≤ 10
5	–	> 10 ≤ 13
6	–	> 13 ≤ 15

Note

The correction factor changes the boiler modulation range.

Further details regarding the individual steps (cont.)

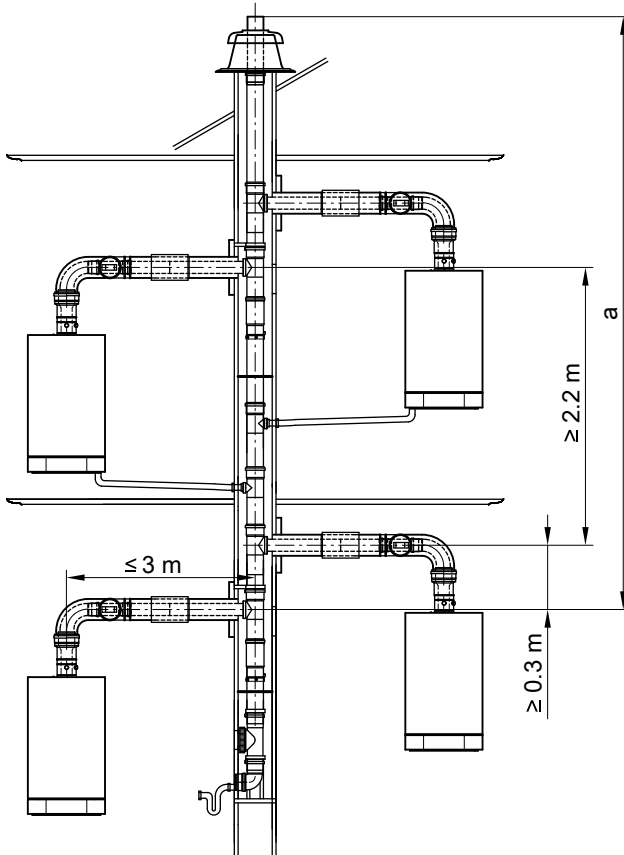

Checking the CO₂ content

The Vitodens 050-W is factory-set for natural gas. During commissioning or maintenance, the CO₂ and CO have to be measured at the boiler flue adaptor test port to check the flue integrity. Depending on the Wobbe index, the CO₂ content fluctuates between 7.5 % and 10.5 %. A CO level of up to 500 ppm during start-up is acceptable.

We recommend measuring the O₂, as this value is unmistakable regarding lambda (air/gas). The O₂ content fluctuates between 7.5 % and 2.2 %. The CO/CO₂ ratio must be less than 0.004. If the actual CO₂ or O₂ and CO values deviate from the stated range, check the balanced flue system for leaks. If the flue installation is OK, change the gas valve.

Further details regarding the individual steps (cont.)

Note

Operate the appliance with uncontaminated combustion air to prevent operating faults and damage.

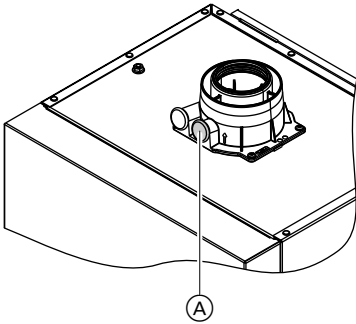

1. Connect a flue gas analyser at flue gas port (A) on the boiler flue connection.
2. Start the boiler. Check for leaks.



Danger

Escaping gas leads to a risk of explosion.
Check all gas equipment for tightness.

Further details regarding the individual steps (cont.)

3. To check the CO₂ content the burner output can be adjusted manually.
 1. Press MODE.
 2. ▲/▼ repeatedly until "SERV" is displayed.
 3. OK to confirm.
"OFF" appears on the display.
 4. Use ▲/▼ to adjust the burner output:

Shown on display	Burner output
—	20 %
--	40 %
---	60 %
----	80 %
-----	100 %

5. Confirm your setting with OK.

Note

This function terminates automatically after 30 min; alternatively use ▲/▼ to set the burner output to "OFF" after checking.

4. Set the upper heating output and check the CO₂ content.
The CO₂ content must be within the following range for the respective gas type. See table.

Gas type	CO ₂ content in %
E or H (G20)	7.5 – 10.5
P (G31)	10.0 – 12.0

Further details regarding the individual steps (cont.)

5. Set the lower heating output and check the CO₂ content.
The CO₂ content must be between 0.3 and 0.9 % below the value of the upper heating output.
6.
 - If the CO₂ content is within the indicated range, continue with point 8.
 - If the CO₂ content is **not** within the indicated range, check the balanced flue system for tightness; remedy any leaks.
Replace gas train if required.
7. Re-check the CO₂ content for the upper and lower heating output.
8. Shut down the boiler. Remove flue gas analyser. Seal flue gas aperture (A).

Further details regarding the individual steps (cont.)

Removing the burner

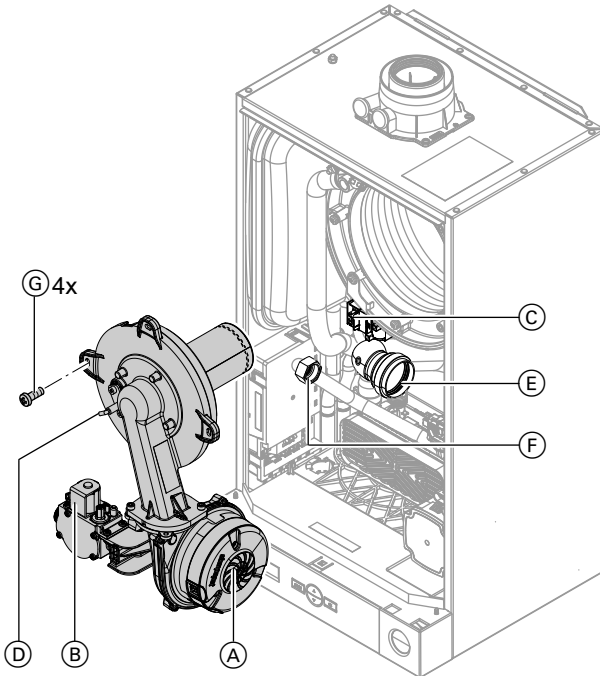

1. Turn off the ON/OFF switch.
2. Shut off the gas supply.
3. Pull the power cables from fan motor (A), gas train (B), ignition unit (C) and electrodes (D).
4. Pull Venturi extension (E) off the fan.
5. Undo the fitting from gas supply pipe (F).
6. Undo 4 screws (G). Remove the burner.



Please note

Prevent damage.

Never rest the burner on the burner gauze assembly.

Checking the burner gasket and burner gauze assembly

Check burner gasket (A) for damage and replace if necessary.

Replace the burner gauze assembly if it is damaged.

Further details regarding the individual steps (cont.)

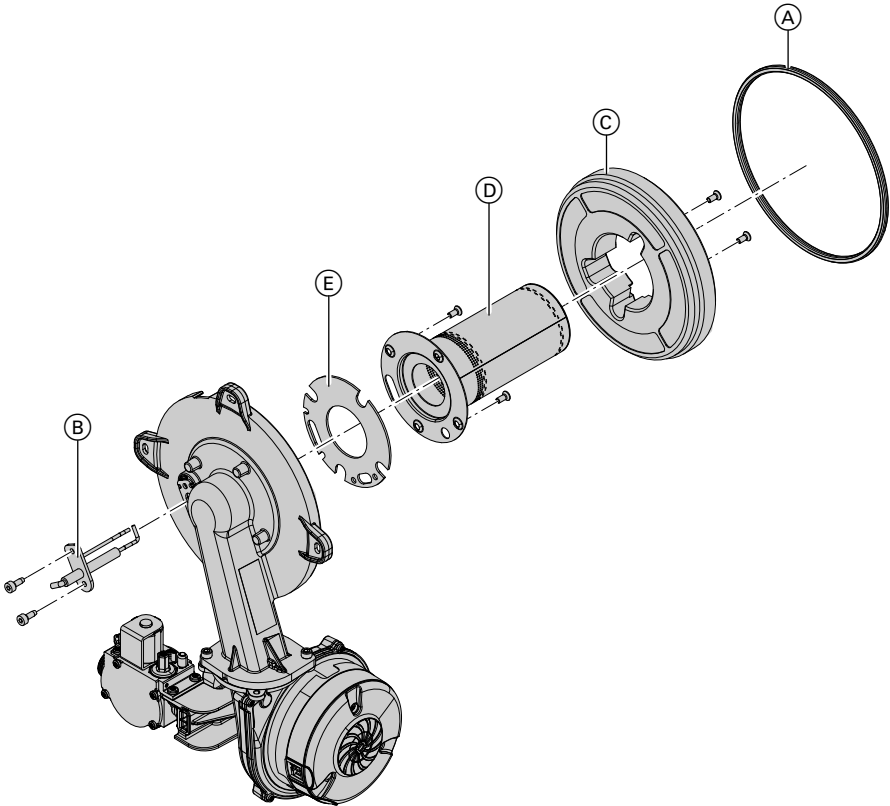

1. Remove electrode (B).
2. Undo 2 Torx screws. Remove thermal insulation ring (C).
3. Undo 2 Torx screws. Remove burner gauze assembly (D) with gasket (E).
4. Insert and secure new burner gauze assembly (D) with new gasket (E).



Please note

Tighten screws enough to ensure the components do not suffer damage and will function correctly.

Further details regarding the individual steps (cont.)

5. Mount thermal insulation ring (C).

! **Please note**
Tighten screws enough to ensure the components do not suffer damage and will function correctly.

6. Fit electrode (B).

! **Please note**
Tighten screws enough to ensure the components do not suffer damage and will function correctly.

Checking and adjusting the electrode

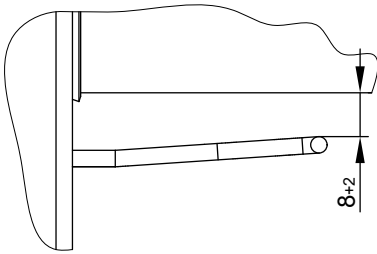

2. Clean the electrode with a small brush (not a wire brush) or emery paper.
3. Check the electrode gaps. If the gaps are not as specified or the electrode is damaged, replace the electrode and gasket and align. Tighten the electrode fixing screws.

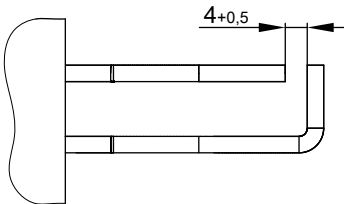

1. Check the electrode for wear and contamination.

! **Please note**
Tighten screws enough to ensure the components do not suffer damage and will function correctly.

Cleaning the heat exchanger

! **Please note**
Scratches to the surfaces of the heat exchanger that come into contact with hot gas can result in corrosion damage.
Never use brushes to clean the heating surfaces.

! **Please note**
Brushing can cause deposits to become lodged in the gaps between the coils.
Never use brushes to clean the heating surfaces.

Further details regarding the individual steps (cont.)

Note

Discolouration on the heat exchanger surface is a normal sign of use. It has no bearing on the function and service life of the heat exchanger.

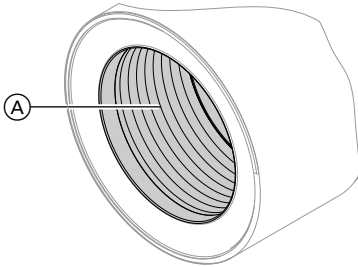

The use of chemical cleaning agents is not required.

1. Use a vacuum cleaner to remove combustion residues from heating surface (A) of the heat exchanger.
2. Flush heating surface (A) with water.
3. Check condensate drain and clean trap. See the following chapter.
4. Flush the heating surface again with water. This will also fill the trap with water.

Further details regarding the individual steps (cont.)

Checking the condensate drain and cleaning the trap

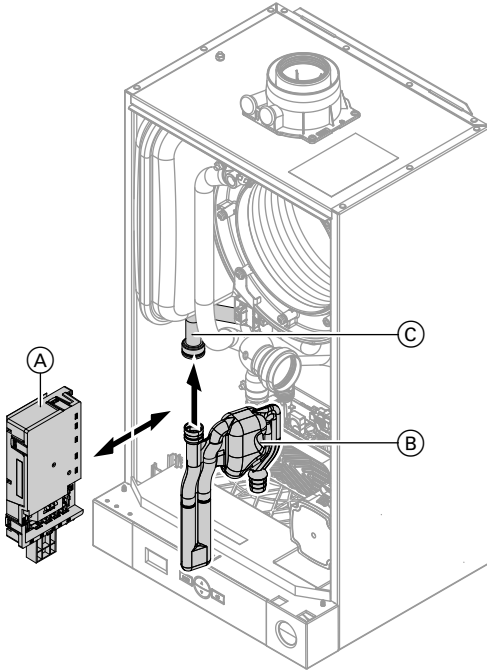

1. Unclip burner control unit (A) and remove. Protect against escaping condensate.
2. Pull trap (B) upwards out of the drain connection.
3. Remove supply hose (C) from trap (B).
4. Clean trap (B).
5. Refit supply hose (C).
6. Refit trap (B) to the drain connection.
7. Install burner control unit (A). Check plugs for correct seating.
8. Fill trap (B) with water. For this, pour approx. 0.3 l of water into the combustion chamber.
9. Check that condensate can drain freely and that the connections are tight.

Further details regarding the individual steps (cont.)

Installing the burner

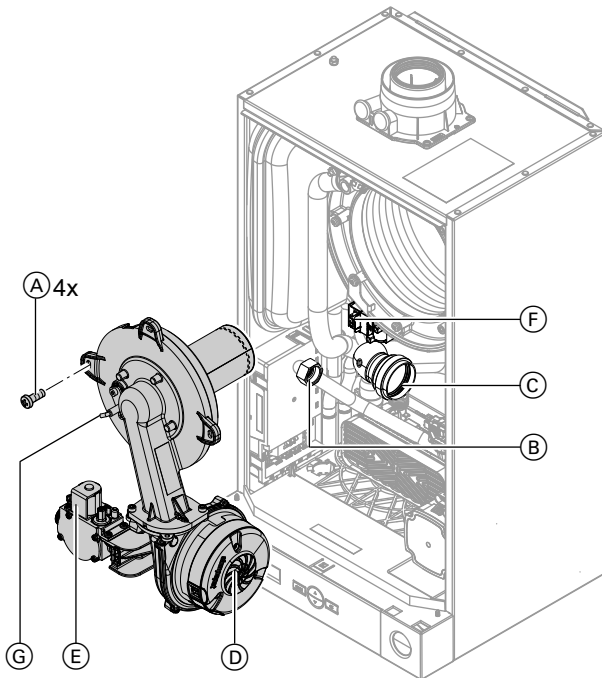

1. Mount the burner. Tighten 4 screws (A) diagonally.



Please note

Tighten screws enough to ensure the components do not suffer damage and will function correctly.

2. Insert new gasket. Secure the fitting of gas supply pipe (B).
3. Refit Venturi extension (C) to the fan.
4. Fit the power cables of fan motor (D), gas train (E), ignition unit (F) and electrodes (G).
5. Reopen the gas supply and switch on the power supply.

Further details regarding the individual steps (cont.)

6. Check the gas connections for tightness.



Danger

Escaping gas leads to a risk of explosion.
Check the fitting for gas tightness.



Please note

The use of leak detection spray can result in faulty operation.
Leak detection spray must not come into contact with electrical contacts or block the diaphragm opening on the gas valve.

Checking the diaphragm expansion vessel and system pressure

Note

*The expansion vessel can lose some of its charge pressure over time. When the boiler heats up, the pressure gauge will indicate a higher pressure of 2 or 3 bar (0.2 or 0.3 MPa). The safety valve may also respond and discharge the excess pressure.
Therefore check the expansion vessel pre-charge pressure annually.*

Check whether the installed expansion vessel is adequate for the system water volume (GB only).
Carry out this test on a cold system.

1. Drain the system until the pressure gauge shows "0".

2. If the pre-charge pressure of the expansion vessel is lower than the static system pressure, top up with nitrogen until the pre-charge pressure is 0.1 to 0.2 bar (10 to 20 kPa) higher than the static system pressure.
3. Top up with water until the charge pressure of the cooled system is at least 1.0 bar (0.1 MPa), and is 0.1 to 0.2 bar (10 to 20 kPa) higher than the pre-charge pressure of the expansion vessel.
Permiss. operating pressure: 3 bar (0.3 MPa)

Checking all gas equipment for tightness at operating pressure



Danger

Escaping gas leads to a risk of explosion.
Check all gas equipment for tightness.



Please note

The use of leak detection spray can result in faulty operation.
Leak detection spray must not come into contact with electrical contacts or block the diaphragm opening on the gas valve.

Further details regarding the individual steps (cont.)

Fitting the front panel

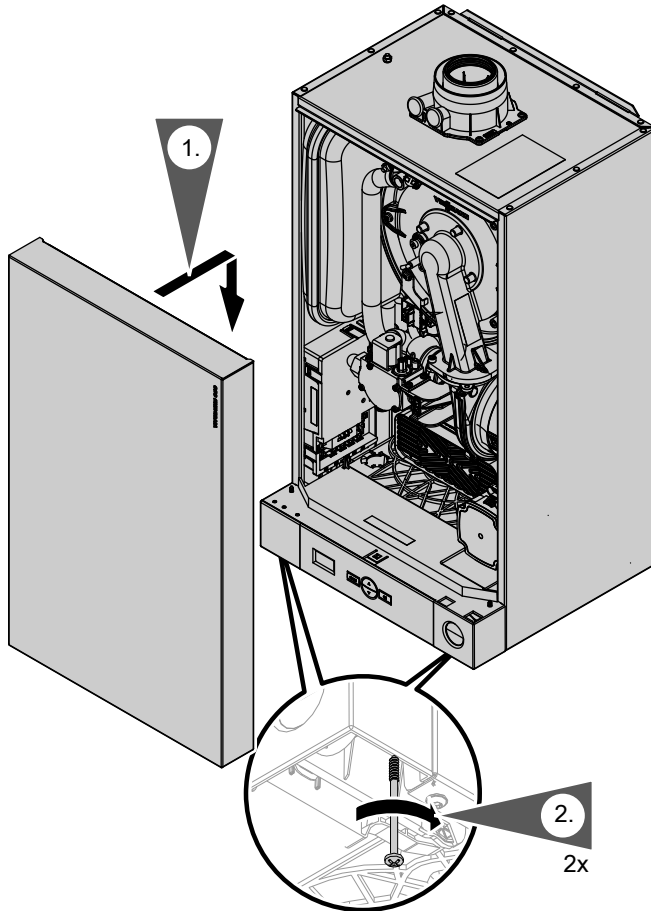

1. Hook the front panel into place.

2. Tighten screws on the underside of the boiler.

Further details regarding the individual steps (cont.)

Instructing the system user

The system installer should hand the operating instructions to the system user and instruct the user in operating the system.

Function sequence and possible faults

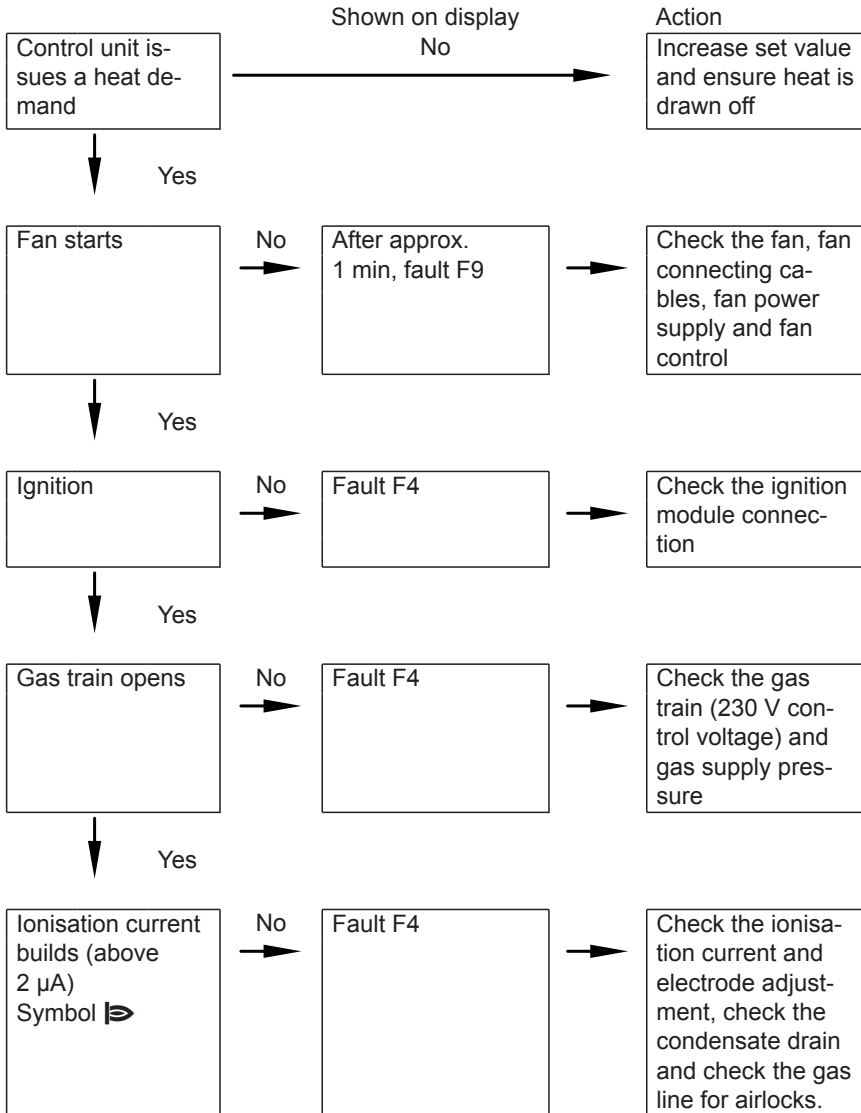

Function sequence and possible faults (cont.)

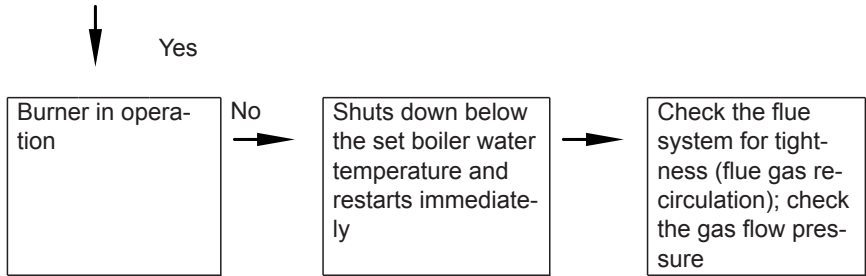

Fault display

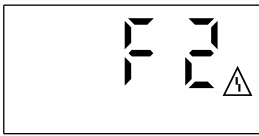

Example

Shown on display

- Faults with lower priority:
Fault code (e.g. "51") is displayed permanently and fault symbol "△" flashes.
- Faults with higher priority:
Fault code (e.g. "F2") and fault symbol "△" flash.

For an explanation of the fault codes, see the following table.

Fault code displayed	System characteristics	Cause	Measures
10	Continuous operation	Short circuit, outside temperature sensor	Check the outside temperature sensor and lead (see page 57).
18	Continuous operation	Lead break, outside temperature sensor	Check the outside temperature sensor and lead (see page 57).
30	Burner blocked	Short circuit, boiler water temperature sensor	Check the boiler water temperature sensor (see page 58).
38	Burner blocked	Lead break, boiler water temperature sensor	Check the boiler water temperature sensor (see page 58).

Fault display (cont.)

Fault code displayed	System characteristics	Cause	Measures
51	No DHW heating	Short circuit, outlet temperature sensor	Check the sensor (see page 60).
52	Burner blocked	Short circuit, flow sensor	Check connections and lead; replace sensor if required.
59	No DHW heating	Lead break, outlet temperature sensor	Check the sensor (see page 60).
5A	Burner blocked	Lead break, flow sensor	Check connections and leads. Replace sensor if required.
A9	Control mode without OpenTherm influence	Communication error, OpenTherm device	Check connections and leads. Replace OpenTherm device if necessary.
b0	Burner blocked	Short circuit, flue gas temperature sensor	Check the sensor (see page 61).
b8	Burner blocked	Lead break, flue gas temperature sensor	Check the sensor (see page 61).
E3	Burner in a fault state	Fault in safety chain	Check the temperature limiter and connecting leads (see page 59).
E5	Burner blocked	Internal fault	Check the ionisation electrode and connecting cables.
F0	Burner blocked	Internal fault	Replace control unit.
F1	Burner in a fault state	Max. flue gas temperature exceeded	Check heating system fill level. Check circulation pump. Vent the system.
F2	Burner in a fault state	Temperature limiter has responded.	Check heating system fill level. Check circulation pump. Vent the system. Check the temperature limiter and connecting leads (see page 59). Press "Reset" (see page 54).

Fault display (cont.)

Fault code displayed	System characteristics	Cause	Measures
F3	Burner in a fault state	Flame signal is already present at burner start.	Check ionisation electrode and connecting cable. Press "Reset" (see page 54).
F4	Burner in a fault state	No flame signal.	Check ignition/ionisation electrode and connecting cable. Check the gas pressure. Check gas train. Check the ignition and ignition module; check the condensate drain. Press "Reset" (see page 54).
F8	Burner in a fault state	Fuel valve closes too late.	Check gas train. Check both control paths. Press "Reset" (see page 54).
F9	Burner in a fault state	Fan speed too low during burner start	Check the fan. Check the fan connecting cables. Check the fan power supply. Check the fan control. Press "Reset" (see page 54).
FA	Burner in a fault state	Fan idle state not reached	Check the fan. Check the fan connecting cables. Check the fan power supply. Check the fan control. Press "Reset" (see page 54).
FC	Burner blocked	Electrical fan control (control unit) faulty	Check fan connecting cable; replace if necessary or replace control unit



Fault display (cont.)

Fault code displayed	System characteristics	Cause	Measures
Fd	Burner blocked	Burner control unit fault	Check ignition electrodes and connecting cables. Check whether a strong interference (EMC) field exists near the appliance. Press "Reset" (see page 54). Replace control unit if fault persists.
FF	Burner blocked	Burner control unit fault	Check ignition electrodes and connecting cables. Check whether a strong interference (EMC) field exists near the appliance. Press "Reset" (see page 54). Replace control unit if fault persists.
—△	Burner blocked	Communication error between burner control unit and programming unit	Check the connecting lead. Press "Reset" (see page 54). Replace burner control unit or programming unit if the fault persists.

Reset (reset burner control unit)

Press **MODE** and **OK** simultaneously.

— is displayed.

If the fault has been removed, "△" extinguishes and the default display is shown or further faults are displayed.

Checking the programming unit software version

Press **MODE** and **▼** simultaneously.

(cont.)

**Please note**

Residual water will escape when the boiler or one of the following components is fitted or removed:

- Water-filled pipework
- Circulation pumps
- Plate heat exchanger
- Components fitted in the heating water or DHW circuit

Water ingress can result in damage to other components.

Protect the following components against ingress of water:

- Control unit (in particular in the service position)
- Electrical components
- Plug-in connections
- Cables and leads

Repairs

Removing the front panel

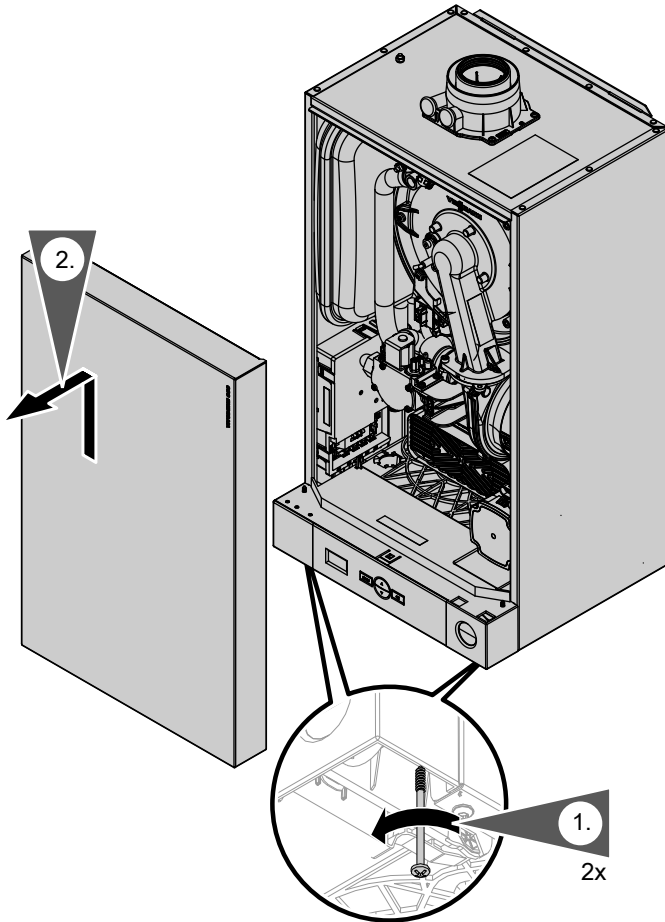

1. Undo the screws on the underside of the boiler. Do not remove.
2. Remove front panel.

Repairs (cont.)

Outside temperature sensor

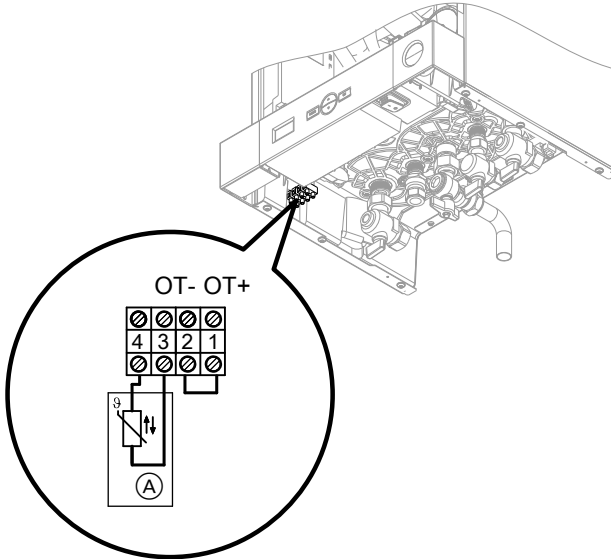

1. Disconnect the leads from outside temperature sensor (A).

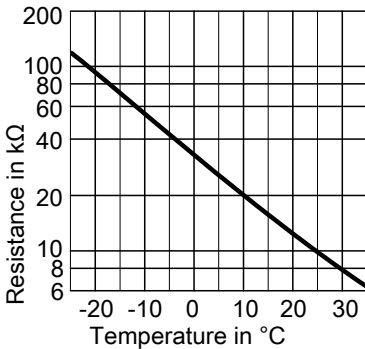

Sensor type: NTC 10 kΩ

2. Check the sensor resistance. Compare with the curve.
3. In the event of severe deviation replace the sensor.

Repairs (cont.)

Boiler water temperature sensor

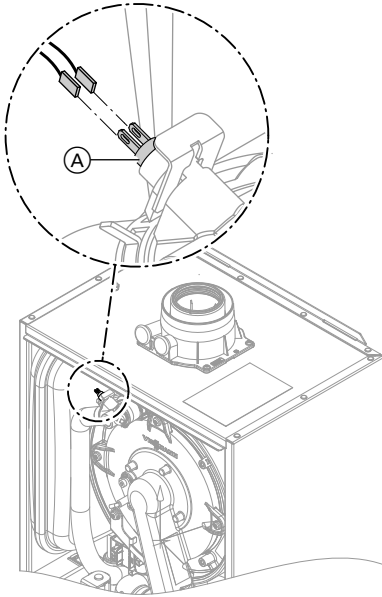

1. Disconnect the leads from boiler water temperature sensor (A). Measure the resistance.

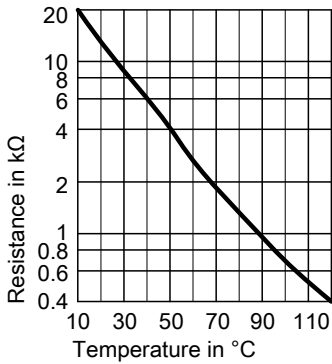

Sensor type: NTC 10 kΩ

2. Check sensor resistance and compare it to the curve.

Repairs (cont.)

3. In the case of severe deviation, drain the boiler on the heating water side and replace the sensor.



Danger

The boiler water temperature sensor is directly immersed in the heating water (risk of scalding). Drain the boiler before replacing the sensor.

Checking the temperature limiter

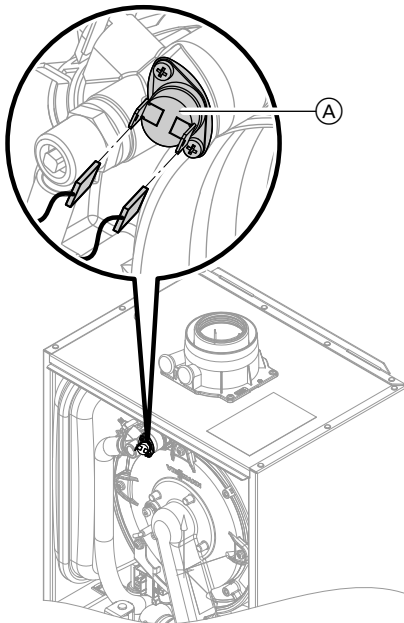

If the burner control unit cannot be reset after a fault shutdown, although the boiler water temperature is below approx. 95 °C, check the temperature limiter.

1. Disconnect the leads from temperature limiter (A).
2. Check the continuity of the temperature limiter with a multimeter.
3. Remove faulty temperature limiter.
4. Install a new temperature limiter.
5. Reset by pressing "Reset" on the control unit (see page 54).

Repairs (cont.)

Checking the outlet temperature sensor

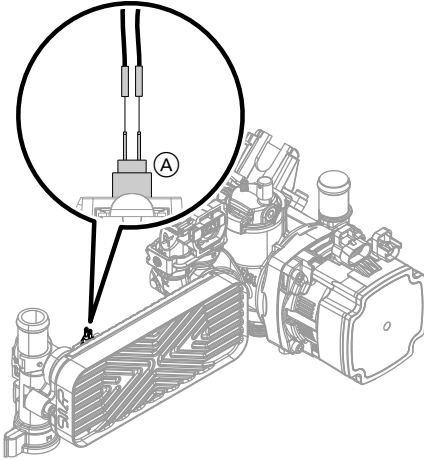

1. Disconnect leads from outlet temperature sensor (A).
2. Check sensor resistance and compare it to the curve.

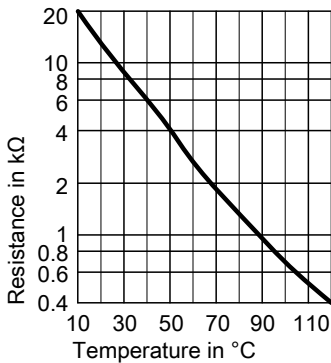

Sensor type: NTC 10 kΩ

3. In the event of severe deviation replace the sensor.

Note

Water may escape when replacing the outlet temperature sensor. Shut off the cold water supply. Drain the DHW line and the plate heat exchanger (on the DHW side).

Repairs (cont.)

Checking the flue gas temperature sensor

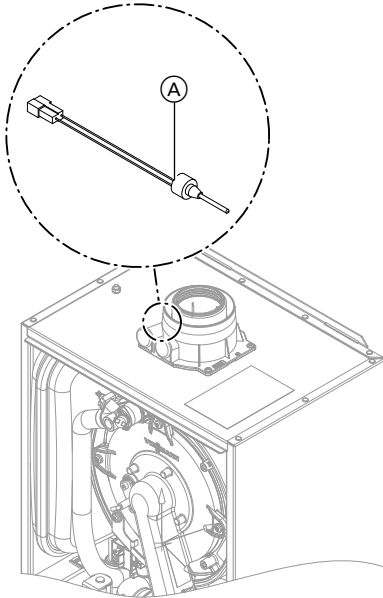

1. Disconnect leads at flue gas temperature sensor (A).
2. Check sensor resistance and compare it to the curve.

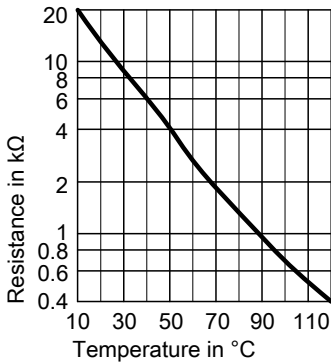

Sensor type: NTC 10 kΩ

3. In the event of severe deviation replace the sensor.

Repairs (cont.)

Replacing the flow limiter

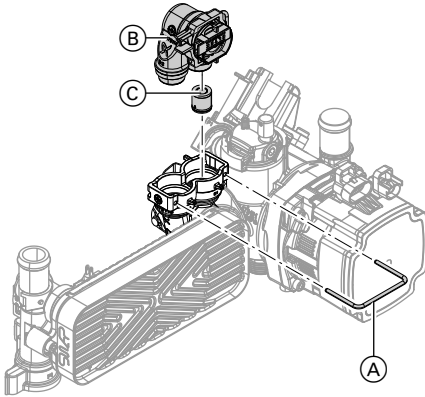

1. Drain the boiler on the DHW side.
2. Pull off spring clip (A).
3. Remove flow sensor (B).
4. Remove faulty flow limiter (C).
5. Check fitted strainer for dirt/contamination. Clean strainer if required.
6. Select a new flow limiter (C) from the table below.

Serial no. (type plate)	Flow rate l/min	Colour
7537906	10	light blue
7537947	14	light pink

7. Insert new flow limiter (C).
8. Mount flow sensor (B) with new gaskets.

Repairs (cont.)

Replacing the flow sensor

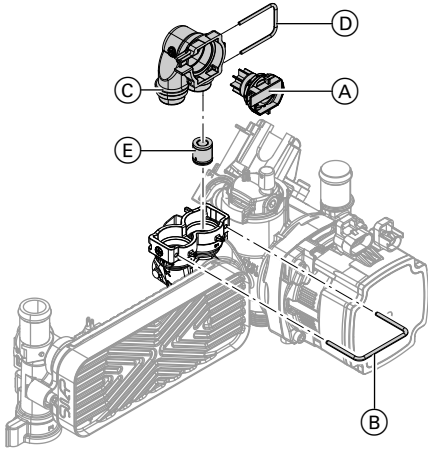

1. Drain the boiler on the DHW side.
2. Disconnect the leads from faulty flow sensor (A).
3. Pull off spring clip (B).
4. Remove casing (C) with flow sensor (A).
5. Pull off spring clip (D) and remove faulty flow sensor (A).
6. Select new flow limiter (E) from the table on page 62.
7. Insert new flow limiter (E).
8. Fit new flow sensor (A) with new gaskets in casing (C). Insert spring clip (D).
9. Insert spring clip (B).
10. Attach leads.

Repairs (cont.)

Checking or replacing the plate heat exchanger

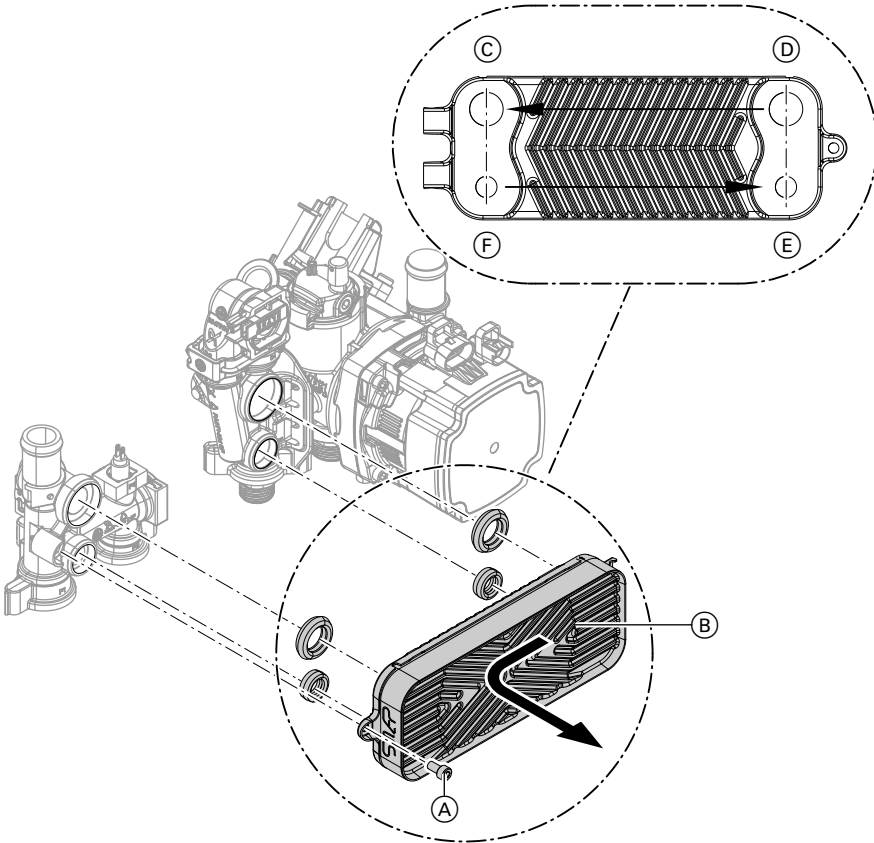

- Ⓒ Heating water return
- Ⓓ Heating water flow
- Ⓔ DHW

- Ⓕ Cold water

1. Shut off and drain the boiler on the heating water and DHW sides.
2. Undo screw Ⓐ on the plate heat exchanger and remove plate heat exchanger Ⓑ with gaskets.

Repairs (cont.)

Note

During and after removal, small amounts of water may trickle from the plate heat exchanger.

3. Check the connections on the DHW side for scaling; clean or replace the plate heat exchanger if required.
4. Check the connections on the heating water side for contamination; clean or replace the plate heat exchanger if required.

5. Install in reverse order using new gaskets.

Note

During installation, ensure the fixing holes are aligned and the gaskets are seated correctly. Fit the plate heat exchanger the right way round.

Checking the fuse

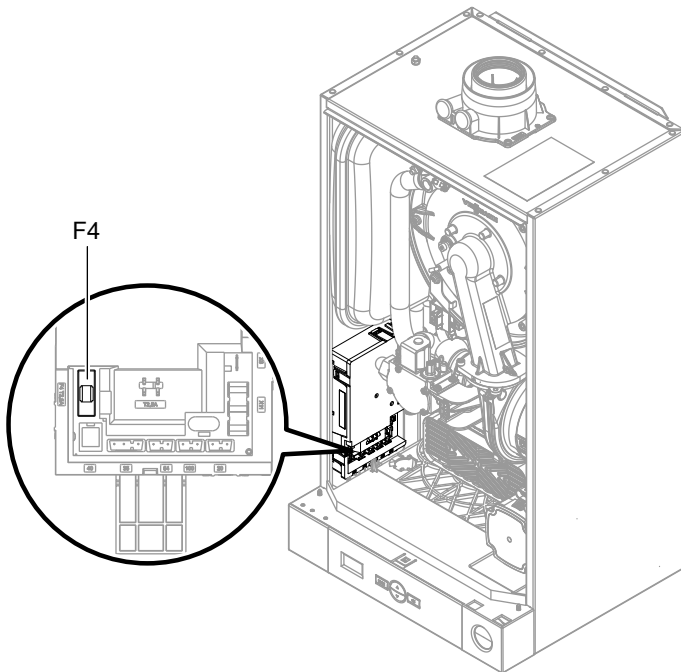

1. Switch off the power supply.
2. Open the control unit enclosure.



Repairs (cont.)

3. Check fuse F4.



Danger

Incorrect or improperly fitted fuses can lead to an increased risk of fire.

- Insert fuses without using any force. Position fuses correctly.
- Only use structurally identical types with the specified response characteristics.

Converting from LPG to natural gas

Removing the gas restrictor

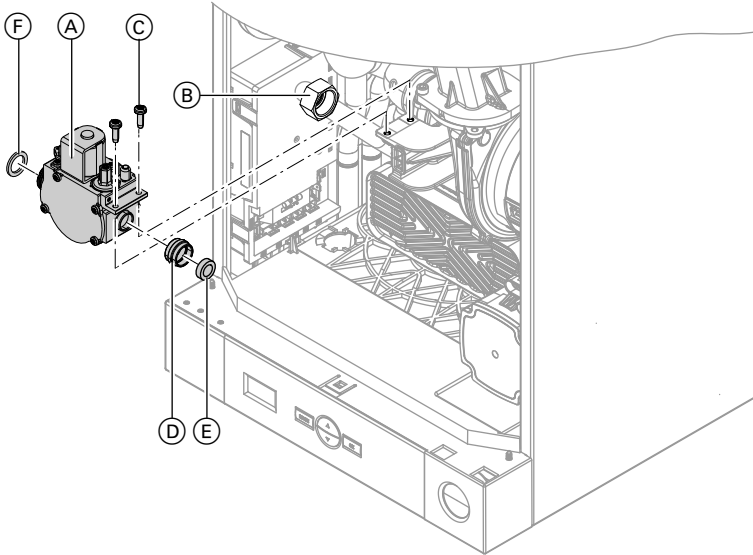

1. Disconnect cable from gas train (A).
2. Undo union nut (B) and remove gas gasket.
3. Undo 2 screws (C) and remove gas train (A).
4. Remove gasket (D) from gas train (A).
5. Remove gas restrictor (E) from gas-gasket (D).
6. Insert gasket (D) in gas train (A).
7. Mount gas train (A) with new gas gasket (F).
8. Remove or void the gas type sticker on the top of the boiler (next to the type plate).



Please note

Tighten screws enough to ensure the components do not suffer damage and will function correctly.

Converting from LPG to natural gas (cont.)

9. Start the boiler and check for leaks.



Danger

Escaping gas leads to a risk of explosion.
Check all gas equipment for tightness.



Please note

The use of leak detection spray can result in faulty operation.
Leak detection spray must not come into contact with electrical contacts or block the diaphragm opening on the gas valve.

Converting the gas type at the control unit

1. Turn on the ON/OFF switch.
2. Press MODE and ▲ simultaneously and hold for 3 s.
"SERV" appears on the display and "I" flashes.
3. Use ▲/▼ to select "5" and confirm with OK.
"1" flashes on the display.
4. Use ▲/▼ to select "0" and confirm with OK.
The burner has been switched to operation with natural gas.
5. Press MODE and ▲ simultaneously and hold for 3 s.
Service mode is terminated. Service mode also terminates automatically after 30 min.
6. Turn the ON/OFF switch off and on again.
The selected gas type is now enabled.

Checking the CO₂ content

See page 37.

Functions and operating conditions in weather-compensated mode

If an outside temperature sensor is connected to the control unit, the boiler water temperature is regulated according to the outside temperature. In line with the selected heating curve, a boiler water temperature is set for the current outside temperature.

The heating curve is selected at the control unit using a code. In the delivered condition, the heating curve with code 20 is set.



Operating instructions

Heating curve for weather-compensated mode

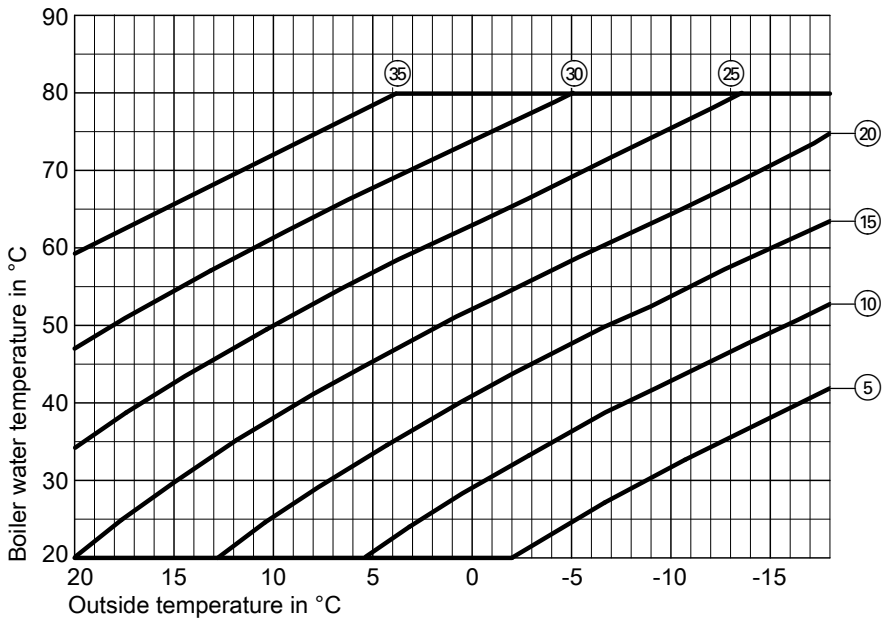

- (X) Indicator for selected heating curve
The setting can be made incrementally between 5 and 35.

Functions and operating conditions in... (cont.)

Frost protection function

The frost protection function requires an outside temperature sensor to be connected. Frost protection function is active at outside temperatures of $< 5\text{ }^{\circ}\text{C}$. The burner starts and the boiler water temperature is held at $20\text{ }^{\circ}\text{C}$.

Connection and wiring diagrams

Overview

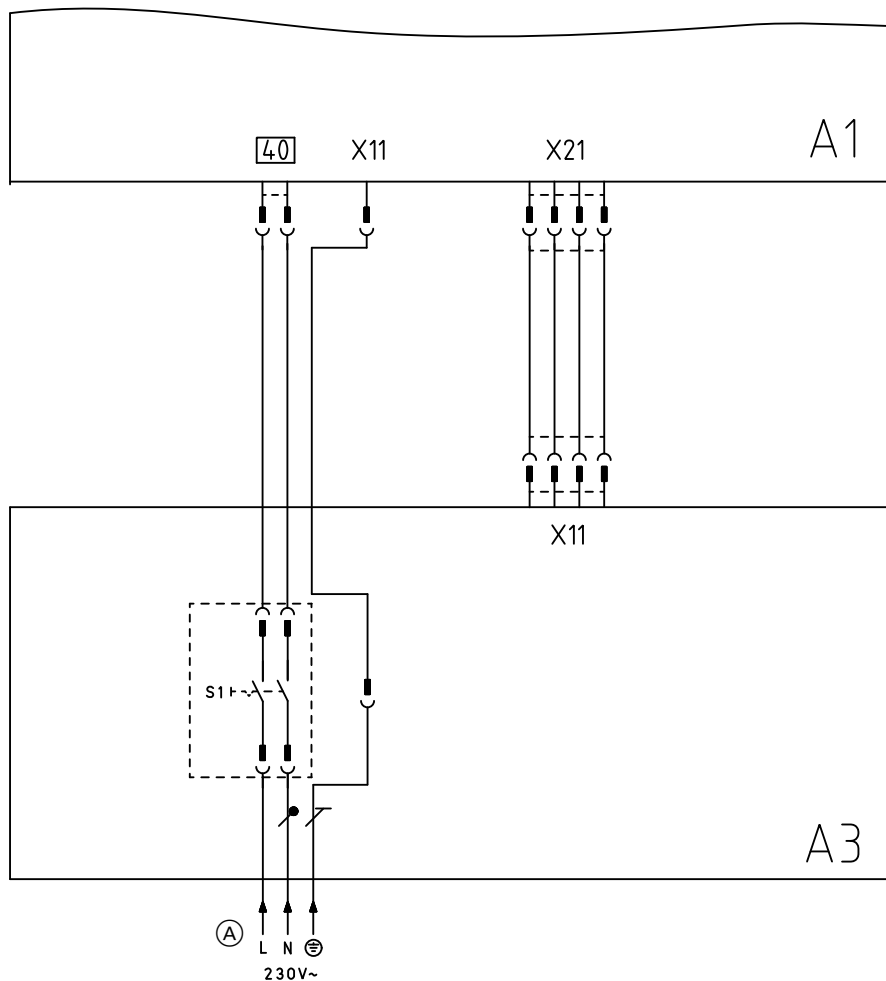

- Ⓐ Power supply
- A1 Main PCB in control unit enclosure
- A3 Programming unit
- S1 ON/OFF switch
- X ... Electrical interface

Connection and wiring diagrams (cont.)

Programming unit

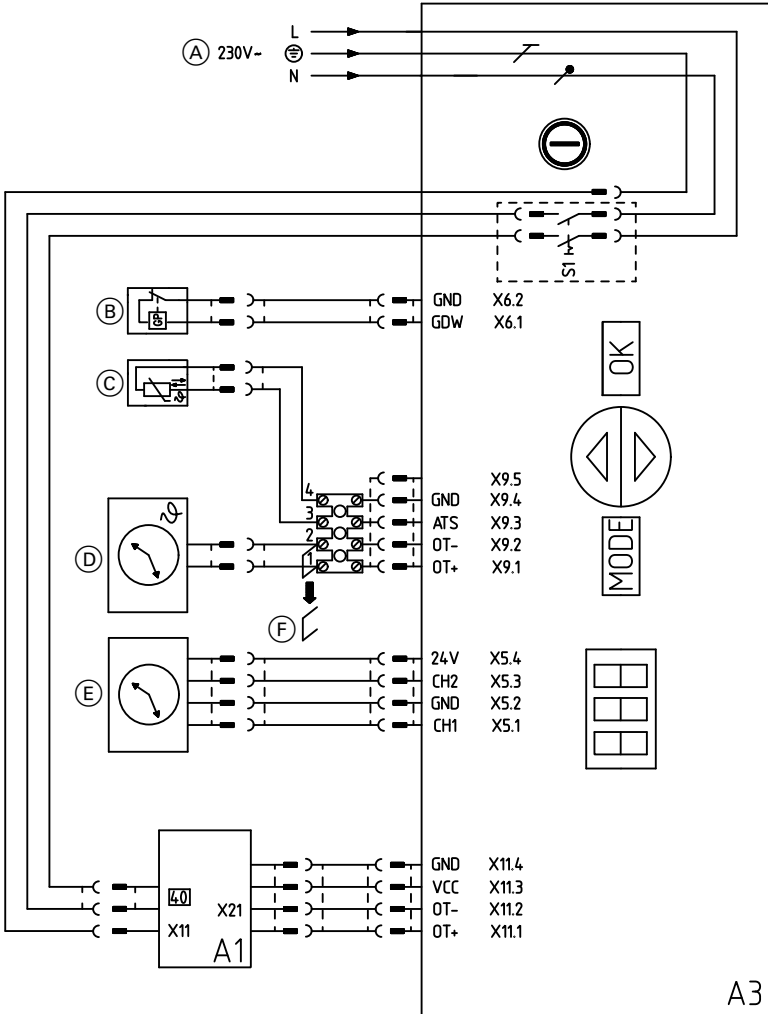

- (A) Power supply
- (B) Gas pressure switch (accessories)
- (C) Outside temperature sensor (accessories)
- (D) Room temperature controller (accessories)
- (E) Time switch or wireless receiver (accessories)

Connection and wiring diagrams (cont.)

ⓕ	Jumper; remove when connecting room temperature controller	A3	Programming unit
A1	Main PCB	S1	ON/OFF switch
		X ...	Electrical interface

Connection and wiring diagrams (cont.)

Ⓑ	Flow sensor	15	Flue gas temperature sensor
Ⓒ	Diverter valve stepper motor	20	Circulation pump 230 V~
Ⓓ	Ionisation electrode	35	Gas solenoid valve
A1	Main PCB	40	Power supply
A2	Switching mode power supply	47	Temperature limiter
A3	Programming unit	54	Ignition
PWM	Circulation pump control	100	Fan motor 230 V~
X ...	Electrical interface	100A	Fan control
3	Boiler water temperature sensor		
4	Outlet temperature sensor		

Overview of assemblies

The following details are required when ordering parts:

- Serial no. (see type plate (A))
- Assembly (from this parts list)
- Position number of the individual part within the assembly (from this parts list)

Overview of assemblies (cont.)

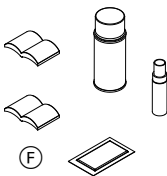
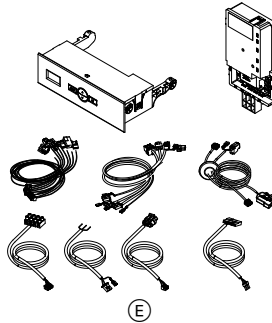
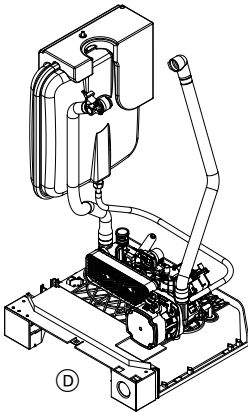
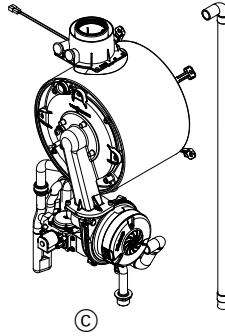
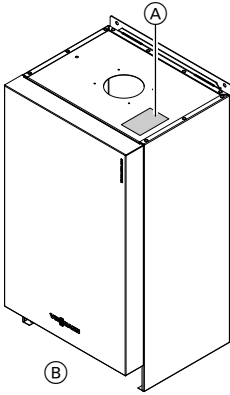

- (A) Type plate
- (B) Casing assembly
- (C) Heat cell assembly

- (D) Hydraulic assembly
- (E) Control unit assembly
- (F) Miscellaneous assembly

5075991

Service



Casing assembly

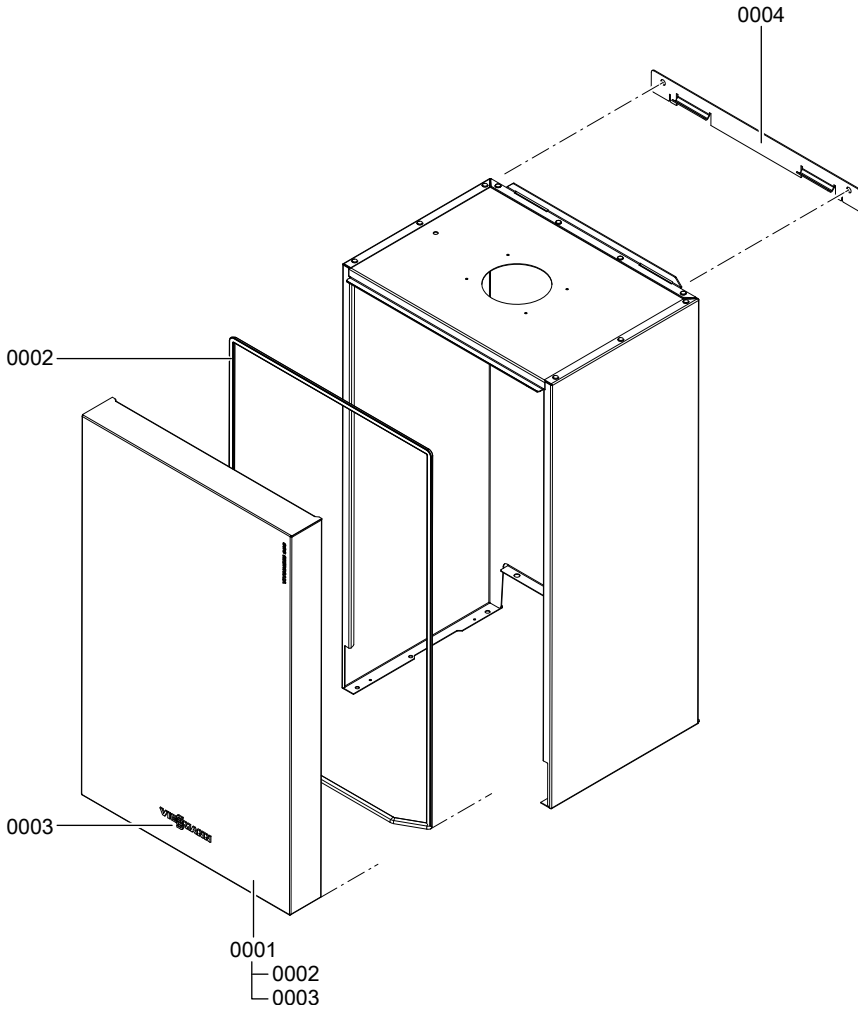

Pos.	Part
0001	Front panel
0002	Profiled seal
0003	Viessmann logo
0004	Wall mounting bracket

Casing assembly (cont.)



Heat cell assembly (cont.)

Pos.	Part
0001	Gasket DN 60
0002	Boiler flue connection
0003	Boiler flue connection plug
0004	Flue gasket
0005	Flue gas temperature sensor
0006	Heat exchanger
0007	Condensate hose
0008	Splash trap
0009	Tee connector \varnothing 19
0010	Gas connection
0011	Gasket A 17 x 24 x 2 (5 pce)
0012	Burner
0013	Thermal insulation block
0014	Heat exchanger mounting bracket (set)
0015	O-ring 20.63 x 2.62 (5 pce)
0016	Corrugated hose 19 x 155 with ferrule/bend
0017	Corrugated hose 19 x 500 with ferrule
0018	Ignition transformer



Burner assembly

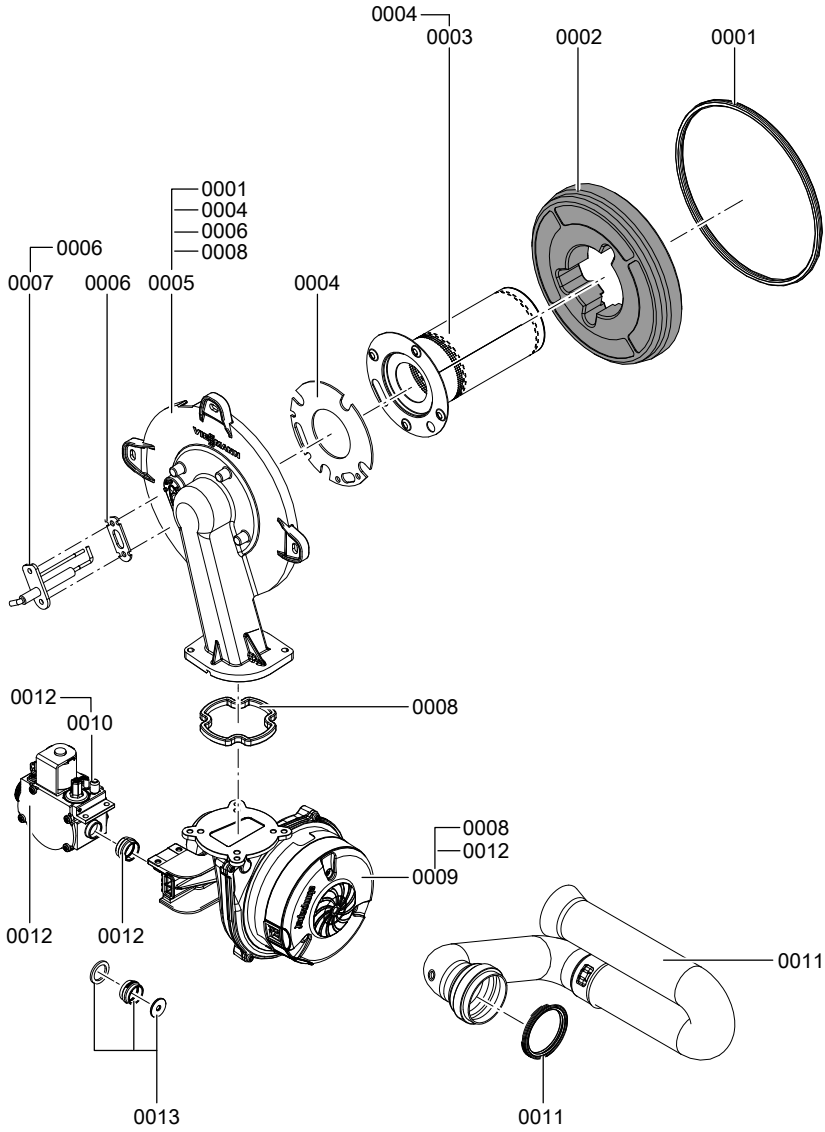

Burner assembly (cont.)

Pos.	Part
0001	Burner gasket \varnothing 187
0002	Thermal insulation ring
0003	Cylinder burner gauze assembly
0004	Burner gauze assembly gasket
0005	Burner door
0006	Gasket, ionisation electrode (5 pce)
0007	Ignition/ionisation electrode
0008	Gasket, burner door flange
0009	Radial fan NRG 118
0010	Gas valve GB-ND 055 E01
0011	Venturi extension
0012	Gasket set G20/G31
0013	Conversion kit G20 - G31



Hydraulic assembly

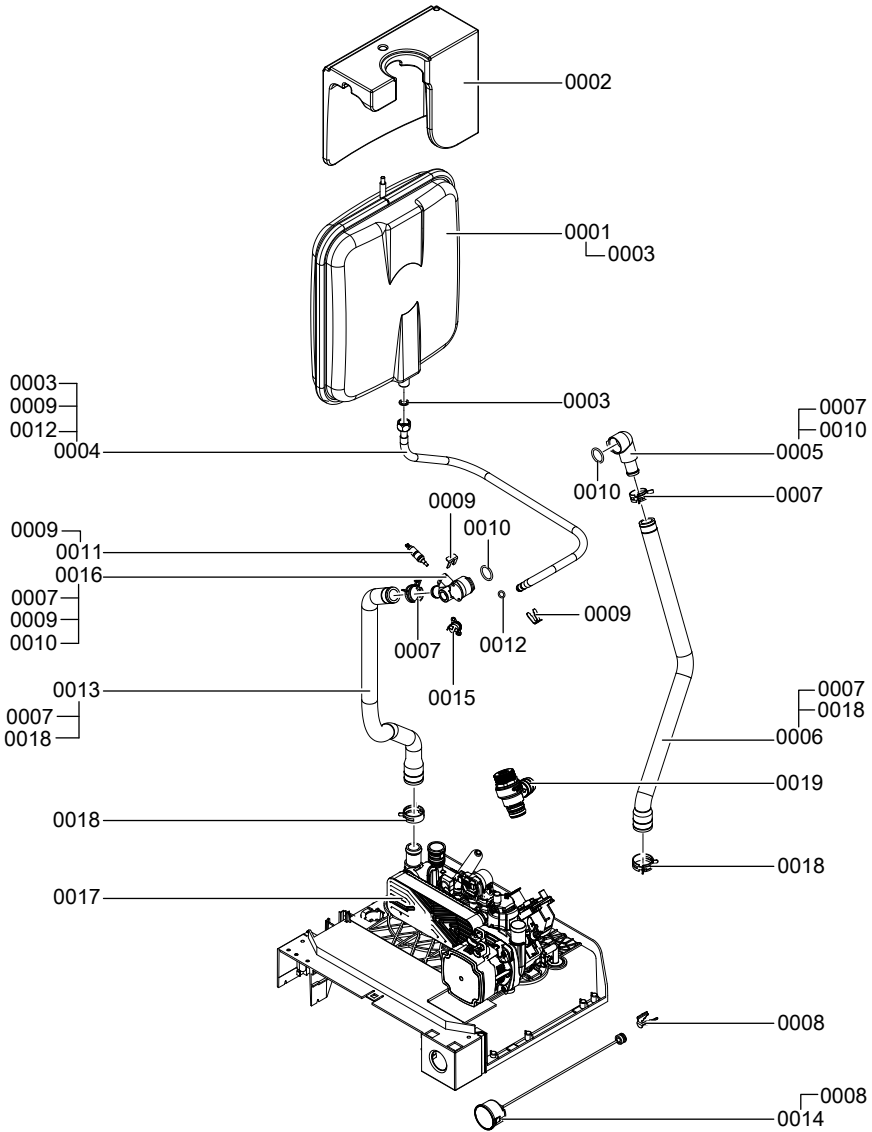

Hydraulic assembly (cont.)

Pos.	Part
0001	Diaphragm expansion vessel CRI 8
0002	Padding profile MAG (diaphragm expansion vessel)
0003	Gasket A 10 x 15 x 1.5 (5 pce)
0004	Connection line MAG (diaphragm expansion vessel) G 3/8
0005	Connection elbow HR (heating return), brass
0006	Profile hose HR (heating return)
0007	Spring clip DN 25 (5 pce)
0008	Clip Ø 10 (5 pce)
0009	Clip Ø 8
0010	O-ring 20.63 x 2.62 (5 pce)
0011	Temperature sensor
0012	Circular seal washer 8 x 2 (5 pce)
0013	Profile hose HV (heating flow)
0014	Pressure gauge
0015	Thermal circuit breaker
0016	Connection elbow HV (heating flow)
0017	Grundfos hydraulics
0018	Spring clip DN 30
0019	Safety valve 3 bar



Grundfos hydraulic assembly (cont.)

Pos.	Part
0001	Flow casing EU1
0002	Temperature sensor
0003	Expansion vessel
0004	O-ring 19.8 x 3.6 (5 pce)
0005	O-ring 16 x 3 (5 pce)
0006	Clip \varnothing 8, narrow (5 pce)
0008	Plate heat exchanger
0009	Circulation pump motor
0010	Return casing
0011	Flow limiter
0012	Stepper motor
0015	Air vent valve
0018	Flow sensor
0019	Clip \varnothing 8
0020	Clip \varnothing 16
0022	Connection elbow
0023	Air box floor
0025	Dummy adaptor, time switch
0028	Gasket set, plate heat exchanger
0030	Tee connector \varnothing 19



Control unit assembly

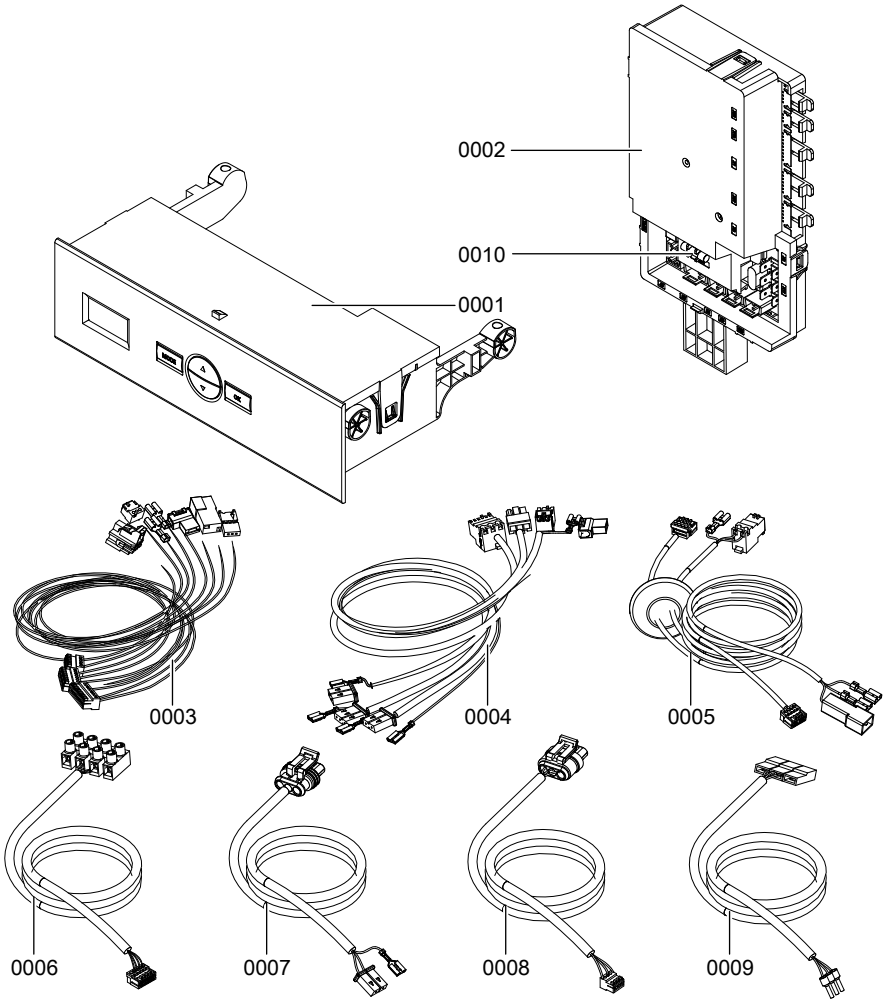

Control unit assembly (cont.)

Pos.	Part
0001	Programming unit
0002	Burner control unit
0003	Cable harness X1/X17/stepper motor
0004	Cable harness 100/35/54/ion
0005	Cable harness, connecting cable X21/GFA/programming unit
0006	OT/ATS (outside temperature sensor) lead
0007	Heating circuit pump connecting cable 20
0008	PWM bus cable
0009	Power cable
0010	Fuse 2.5 A (slow) 250 V



Miscellaneous assembly

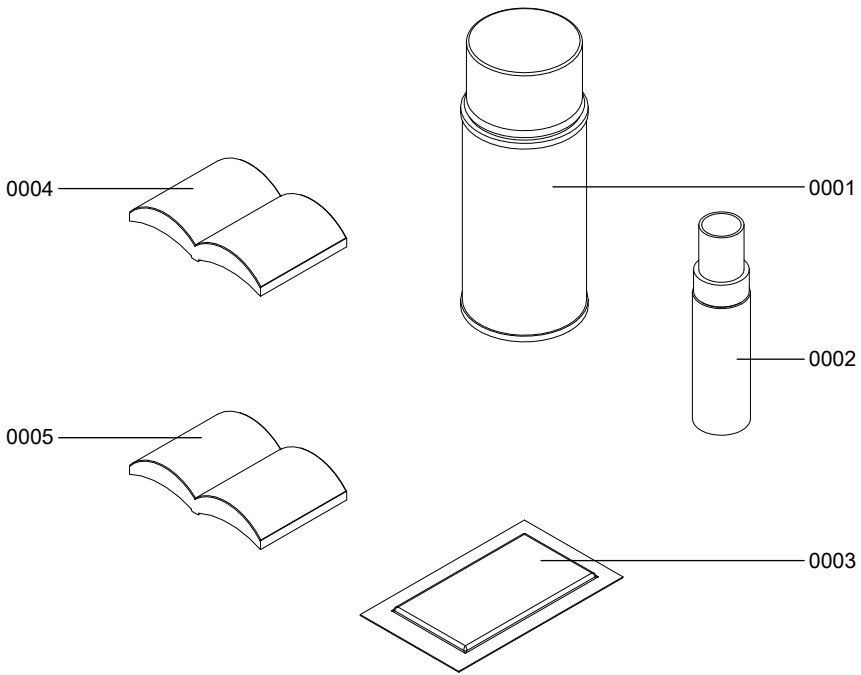

Pos.	Part
0001	Touch-up spray paint, white, 150 ml can
0002	Touch-up paint stick, white
0003	Special grease
0004	Operating instructions
0005	Installation and service instructions

Specification

Gas boiler, category II _{2H3P}

Rated heating output range in heating mode			
T_F/T_R 50/30 °C	kW	6.5 – 24	8.8 – 33
T_F/T_R 80/60 °C	kW	5.9 – 22.1	8.0 – 30.3
Rated heating output range	kW	5.9 – 29	8.0 – 35
For DHW heating			
Rated heating input range	kW	6.1 – 22.4	8.2 – 30.9
Connection values ^{*1}			
Relative to the max. load for:			
- Natural gas H	m ³ /h	2.37	3.28
- LPG P	kg/h	1.71	2.36
DHW heating			
Permiss. operating pressure	bar	10	10
	MPa	1.0	1.0
Min. operating pressure, cold water	bar	1	1
	MPa	0.1	0.1
Nominal water flow rate	l/min	13.8	16.7
at ΔT 30 K (to EN 13203)			
Set flow rate (max.)	l/min	10	14
Min. flow rate	l/min	2.1	2.1
Power consumption (max.)	W	72	110
Rated voltage	V~	230	
Rated frequency	Hz	50	
Rated current	A	2.0	
Backup fuse (max.)	A	3	
IP rating		IP X4 to EN 60529	
Protection class		I	
Permissible ambient temperature			
■ During operation	°C	-5 to +40	
■ During storage and transport	°C	-35 to +65	
Temperature limiter setting	°C	100 (fixed)	
Product ID		CE-0085CP0029	

^{*1} The supply values are only for reference (e.g. in the gas contract application) or for a supplementary, rough estimate to check the volumetric settings. Due to factory settings, the gas pressure must not be altered from these values. Reference: 15 °C, 1013 mbar (101.3 kPa).

Final decommissioning and disposal

Viessmann products can be recycled. Components and substances from the system are not part of ordinary household waste.

For decommissioning the system, isolate the system from the power supply and allow components to cool down where appropriate.

All components must be disposed of correctly.

Declaration of conformity

Vitodens 050-W, type BPJD

We, Viessmann Werke GmbH & Co. KG, D-35107 Allendorf, declare as sole responsible body that the named product complies with the provisions of the following directives and regulations:

92/42/EEC	Efficiency Directive
2009/142/EC	Gas Appliances Directive ^{*2}
2016/426/EU	Gas Appliances Regulation ^{*3}
2014/30/EU	EMC Directive
2014/35/EU	Low Voltage Directive

Applied standards:

EN 297:1994 + A1:1994 + A2:1996 + A3:1996 + A4:2004 + A5:1998 + A6:2003
 EN 483 A4:2010-07
 EN 625: 1995-10
 EN 677:1998-08
 EN 12897: 2009-09
 EN 55014-1: 2006 + A1:2009 + A2:2011
 EN 55014-2: 2015
 EN 60335-1: 2012 / AC:2014
 EN 60335-2-102: 2006 + A1:2010
 EN 61000-3-2: 2014
 EN 61000-3-3: 2013
 EN 62233: 2008 + Corrigendum:2008-11

In accordance with the listed directives, this product is designated with

CE-0085

Allendorf, 1 August 2017

Viessmann Werke GmbH & Co. KG



Authorised signatory Reiner Jansen
 Head of Strategic Quality Management

Declaration of conformity (cont.)

Manufacturer's declaration

This product meets the requirements of the Efficiency Directive (92/42/EEC) for **condensing boilers**.

Keyword index

B

Boiler water temperature sensor	58
Burner gasket.....	41
Burner gauze assembly.....	41
Burner installation.....	46
Burner removal.....	41

C

Combustion chamber cleaning.....	43
Commissioning.....	27
Condensate.....	20
Condensate drain.....	20, 45
Connection diagram.....	71
– Control unit.....	74
– Programming unit.....	72
Connections.....	18
Connections on the water side.....	18

E

Electrical connections.....	23
-----------------------------	----

F

Fault code.....	51
Fault display.....	51
Filling function.....	27
Flow limiter.....	62
Flow sensor.....	63
Flue gas temperature sensor.....	61
Flue pipe.....	21
Frost limit.....	70
Frost protection.....	70
Function sequence.....	50
Fuse.....	65

G

Gas connection.....	19
Gas supply pressure.....	31
Gas train	30
Gas type conversion.....	67
– LPG.....	29
– Natural gas.....	67

H

Heat exchanger cleaning.....	43
Heating curve.....	69

I

Ignition.....	43
Ignition electrode.....	43
Ionisation electrode.....	43

M

Max. heating output.....	31
--------------------------	----

O

Outlet temperature sensor.....	60
Output adjustment	
– Shared connection.....	33
Output matching to flue system.....	32
Output reduction.....	31
Outside temperature sensor.....	24, 57

P

Plate heat exchanger.....	64
Power supply.....	24
Programming unit, opening.....	22

R

Reset.....	54
------------	----

S

Safety chain	59
Safety valve.....	20
Shared flue system connection.....	33
Software version.....	54
Static pressure.....	30
Supply pressure.....	29
System filling.....	27, 29
System pressure.....	29

T

Temperature limiter.....	59
Trap.....	21, 45
Troubleshooting.....	56

Keyword index (cont.)

V

Ventilation air pipe.....21

W

Wall mounting..... 15

Weather-compensated mode.....69

Viessmann Werke GmbH & Co. KG
D-35107 Allendorf
Telephone: +49 6452 70-0
Fax: +49 6452 70-2780
www.viessmann.com

Viessmann Limited
Hortonwood 30, Telford
Shropshire, TF1 7YP, GB
Telephone: +44 1952 675000
Fax: +44 1952 675040
E-mail: info-uk@viessmann.com

5675991 Subject to technical modifications.